

	Description	Assembly Order No.
Style 153-2	Blind nuts, 1/4 NPT	WO1-358-8158
	Blind nuts, 3/4 NPT	WO1-358-8157
Two Ply Bellows	Ribbed neck aluminum bead bead rings (equal spacing) 1 7/8 bolts, nuts, washers	WO1-358-8165
	Rubber bellows only	WO1-358-1201
Assembly weight		17.1 lbs.

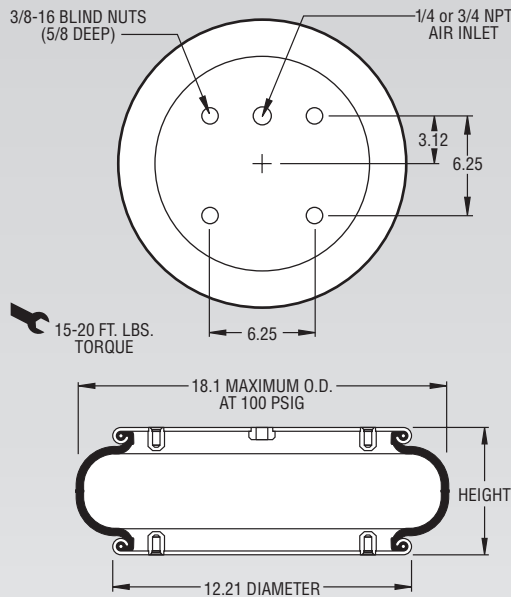

NOTE: A bead plate part is shown. This part is also available with bead rings. See pages 8-10 for explanation.

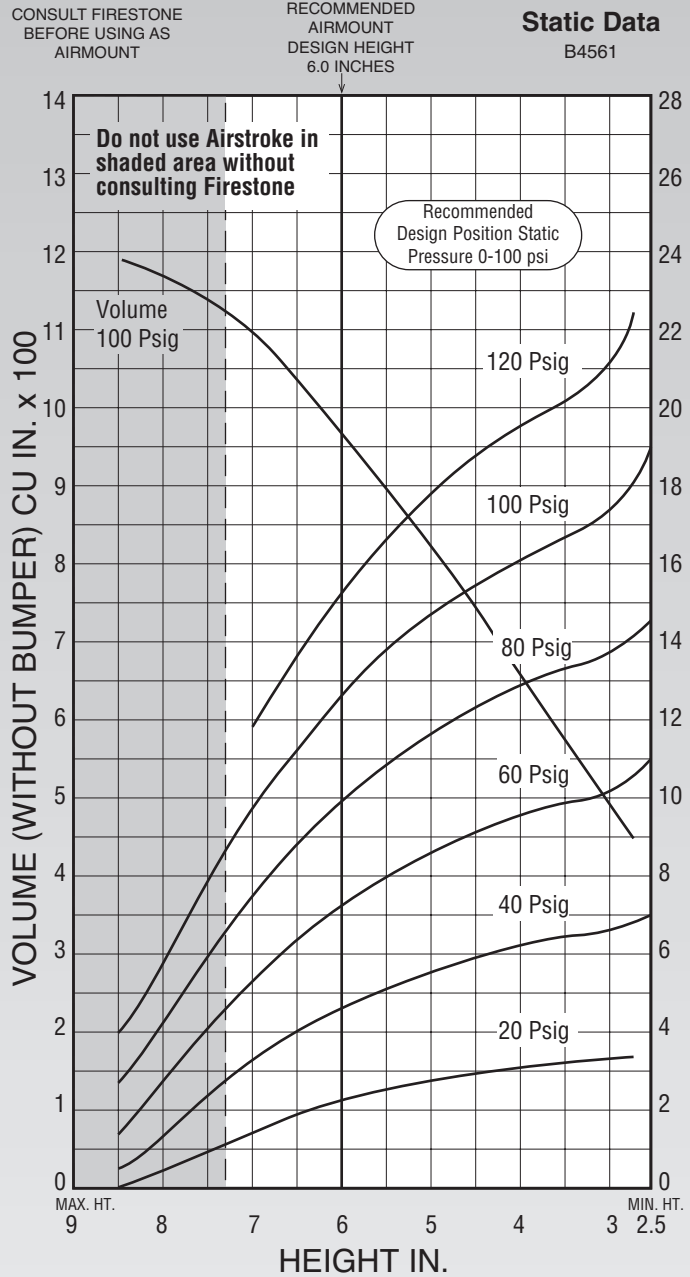

See page 12 for instructions on how to use chart.

Dynamic Characteristics at 6.0 in. Design Height (Required for Airmount isolator design only)				
Volume @ 100 PSIG = 981 in ³			Natural Frequency	
Gage Pressure (PSIG)	Load (lbs.)	Spring Rate (lbs./in.)	CPM	HZ
40	4,564	2,202	131	2.18
60	7,048	3,153	126	2.10
80	9,682	4,031	121	2.02
100	12,385	4,958	119	1.98

Force Table (Use for Airstroke™ actuator design)						
Assembly Height (in.)	Volume @ 100 PSIG (in ³)	Pounds Force				
		@20 PSIG	@40 PSIG	@60 PSIG	@80 PSIG	@100 PSIG
8.0	1,169	425	1,260	2,566	4,038	5,636
7.0	1,094	1,423	3,210	5,194	7,334	9,528
6.0	981	2,140	4,564	7,048	9,682	12,385
5.0	840	2,676	5,476	8,458	11,440	14,471
4.0	679	3,051	6,153	9,478	12,738	15,965
3.0	510	3,219	6,609	10,069	13,550	17,218

ADVANTAGES OF FIRESTONE AIRSTROKE™ ACTUATORS

Why use an Airstroke actuator (rather than air or hydraulic cylinder) for actuation?

LOW COST

Generally, initial cost is one-half or less than conventional pneumatic or hydraulic cylinders of the same force capabilities. This initial cost advantage is many times greater in the larger sizes.

WIDE SIZE RANGE

Airstroke actuators are available in sizes ranging from 2.2 inches to 37 inches in diameter. The force capability is 100,000 pounds. Strokes of up to 14 inches are possible.

DURABLE FOR LONG LIFE

Airstroke actuators are a further application of Firestone's time proven Airide springs for truck and bus suspensions. The long life and durability necessary for millions of miles of heavy duty suspension use under adverse environmental conditions are also important factors in machine design.

NO MAINTENANCE OR LUBRICATION REQUIRED

NO INTERNAL ROD OR PISTON

Airstroke actuators have no internal rod, piston, or sliding seals as do conventional cylinders. This allows for the design of Airstroke actuators into applications where dirt or grit would destroy the seals on conventional cylinders.

FRICTION FREE FOR IMMEDIATE RESPONSE

Since Airstroke actuators have no sliding seals, there is no breakaway friction as with conventional cylinders

FLEXIBLE MEDIA

An Airstroke actuator can do its work with either a liquid or gas (Please see page 14 for acceptable media choices.)

ANGULAR CAPABILITY

An Airstroke possesses the unique capability of stroking through an arc without a clevis. Angular motion of up to 30 degrees is possible, along with the design advantage of generally less complex linkages.

SIDE LOADING CAPABILITY

Airstroke actuators, within certain limits, are not affected by side loads as are conventional cylinders. This misalignment capability eliminates potential rod bending, scoring, and excessive seal wear common to conventional cylinders.

COMPACT STARTING HEIGHT

Airstroke actuators have a low profile compared to conventional cylinders. Our smallest Airstroke actuator (2.2 inch/dia.) collapses to just 1.1 inches in height, while our largest triple convoluted Airstroke (37 inch/dia.) will collapse to a very compact 5.5 inches.

FACTORY SEALED AND TESTED

Most Airstroke actuators feature Firestone's proven concept of crimped end plates. The crimped design allows for preshipment testing and quicker installation on equipment.

PLEASE REFER TO PAGE 15 FOR A THOROUGH DISCUSSION OF ACTUATION.

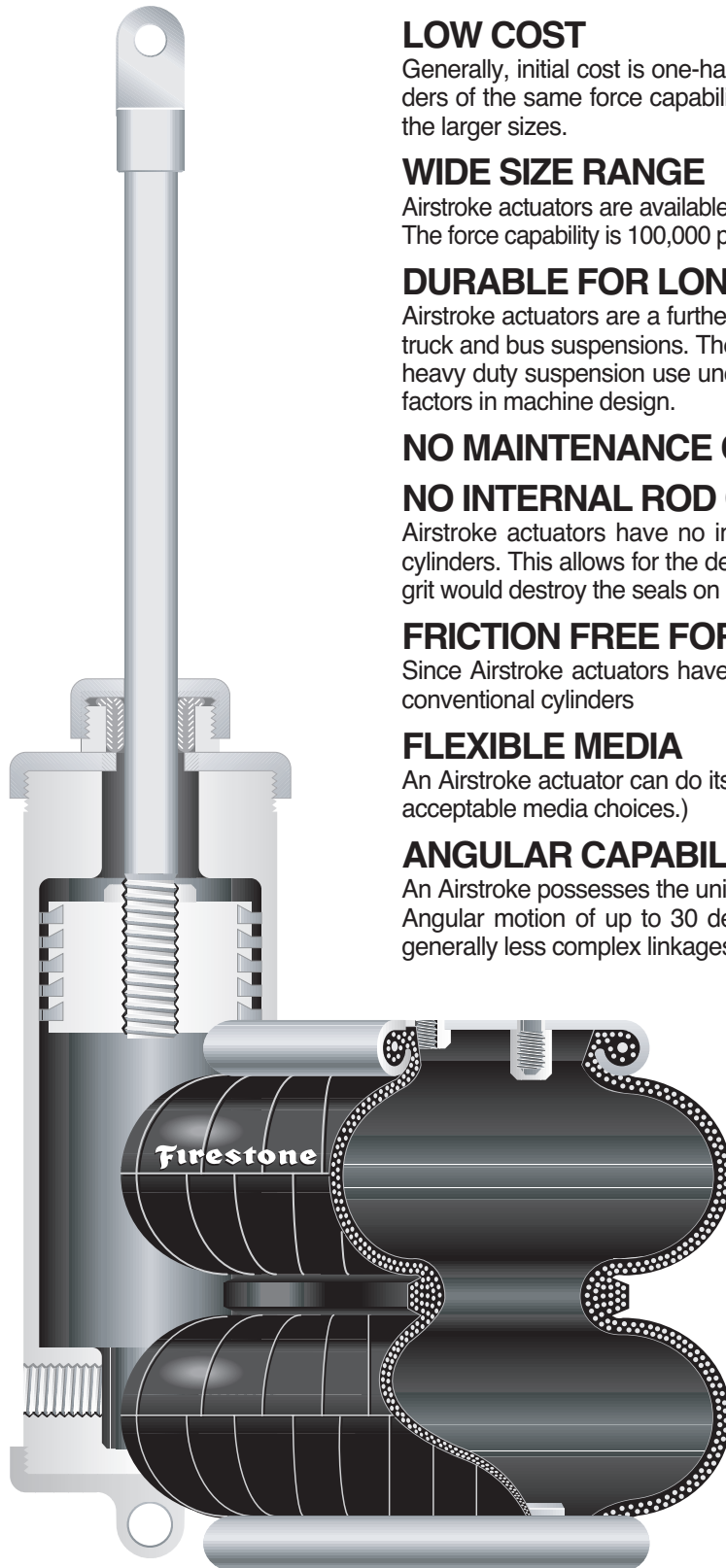

ADVANTAGES OF FIRESTONE AIRMOUNT™ ISOLATORS

Why use an Airmount isolator rather than a coil spring or other type of isolator?

UNSURPASSED ISOLATION CAPABILITY

Airmount isolators can provide the highest degree of isolation of any type vibration isolator. System natural frequencies as low as 60 cycles per minute (1 Hertz) are available. The addition of an auxiliary reservoir can provide even lower system frequencies. In order to achieve similar results from a conventional coil spring isolator, a real deflection of 9 inches would be required.



CONSTANT ISOLATION EFFICIENCY

Airmount isolators are unique in that the system's natural frequency does not change significantly with changes in load. This unique feature, combined with accurate height control, will allow the use of the same Airmount isolator at each mounting point of an unevenly loaded machine.

ACCURATE HEIGHT CONTROL

Airmount isolators provide accurate height control through regulation of internal air pressure. This feature eliminates the fatigue and permanent set found in the use of other types of vibration isolators.

WIDE SIZE RANGE

Airmount isolators are capable of isolating loads of 100 pounds per mounting point to over 100,000 pounds per mounting point.

COMPACT INSTALLED HEIGHT

Airmount isolators can carry the loads and provide the isolation described above at installed heights as low as 2.5 inches. Coil springs providing equal isolation would require a free height of 5 to 25 inches.

EXTENDED EQUIPMENT LIFE

Airmount isolators extend equipment life through their superior isolation capabilities.

EFFECTIVE NOISE REDUCTION

Airmount isolators reduce structurally transmitted noise. Airmount isolators are also quiet in themselves, since there is no spring chatter as found in conventional coil springs.

VERSATILE

Airmount isolators can be used not only to protect structural members from vibrating machinery, but are also widely used to protect delicate equipment from structurally transmitted vibration.

PLEASE REFER TO PAGE 21 FOR A THOROUGH DISCUSSION OF VIBRATION ISOLATION.

AIR SPRING BELLOWS CONSTRUCTION

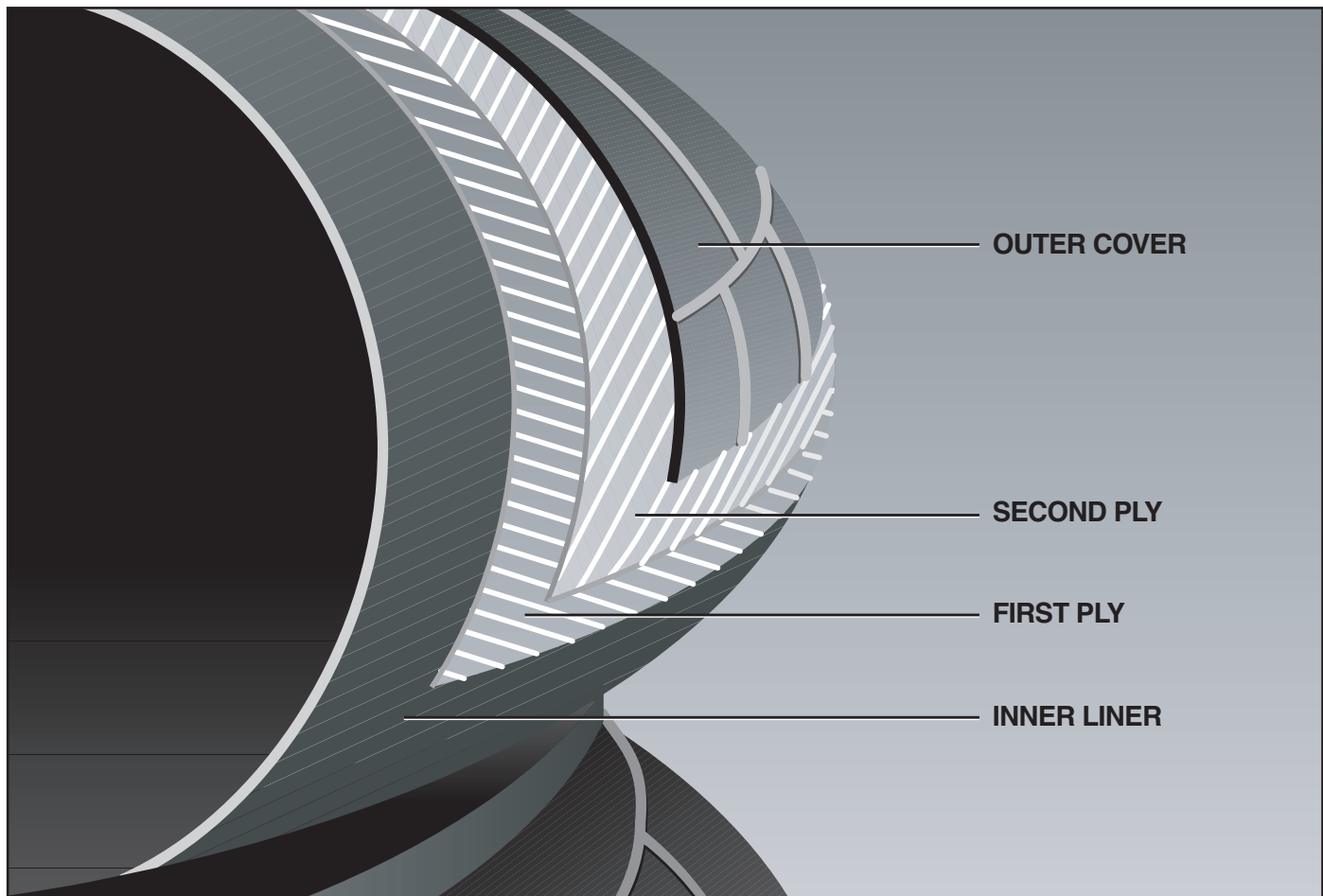

An air spring is a carefully designed rubber/fabric bellows which contains a column of compressed air. The rubber bellows itself does not provide force or support load. This is done by the column of air.

Firestone air springs are highly engineered elastomeric bellows with specially designed metal end closures. Our standard two ply air spring bellows is actually made up of four layers:

- a. An inner liner of calendared rubber.
- b. One ply of fabric reinforced rubber.
- c. A second ply of fabric-reinforced rubber (with the cords at a specific bias angle to the first ply).
- d. An outer cover of calendared rubber.

Many of our air springs are also available in high strength construction for higher pressures (see page 14 for more detailed information). In this case, there are four plies of fabric-reinforced rubber, with an inner liner and outer cover.

The two ply air spring is standard. Where high strength construction is available, it is so noted in the selection guide (page 32), on the individual Data sheets, and in the index (page 107). If the high strength style number is omitted, then it is not currently available in that particular part.

Each air spring bellows is identified by a style number. This style number is molded into the bellows during the curing (or vulcanization) process. Examples would be 16, 22, 313, 1T15M-6, etc... This identifies *only* the rubber/fabric bellows and *not the complete assembly*. There are several different end closure options available for most air springs; therefore, please always specify both the style number and the complete **assembly order number (AON)**. An example would be: Style #22, assembly order number W01-M58-6180. Both numbers are given on the individual data sheets.

END CLOSURE OPTIONS

Each individual air spring data sheet shows a cross sectional view of the most popular end closure option for that part. For convoluted air springs 16 inches in diameter and less, and for the reversible sleeve air springs, *the Crimped Bead Plate*

attachment is shown. For convoluted air springs 17 inches in diameter and larger, a *Bead Ring attachment is shown.* An air spring of each variety, with proper terminology for each, is shown on the following pages.

CRIMPED BEAD PLATES

CONVOLUTED AIR SPRINGS

(#22 is shown)



AIR INLET

1/4" NPT is standard. 3/4" NPT is also available for most parts. (See the data sheet order block on each specific part).

BLIND NUT

3/8-16 UNC thread x 5/8" deep (two or four per each plate depending on part size). Used for mounting the part.

UPPER BEAD PLATE

(9 gauge carbon steel, .149"). Permanently crimped to bellows to form an airtight assembly which allows for leak testing before the unit leaves the factory. Zinc/chromate plated for rust protection.

GIRDLE HOOP

Wire wound type shown, molded into the bellows.

BELLOWS

Wall gauge is approximately 1/4". See page 5 for detailed information.

LOWER BEAD PLATE

Usually the same as upper bead plate, except without air inlet.

REVERSIBLE SLEEVE AIR SPRINGS

(1T15M-6 is shown)



AIR INLET 1/4" NPT is standard. 3/4" NPT is also available for most parts. (See the data sheet order block on each specific part).

BLIND NUT 3/8-16 UNC thread x 5/8" deep (two or four per each plate depending on part size). Used for mounting the part.

BEAD PLATE (9 gauge carbon steel, .149"). Permanently crimped to bellows to form an airtight assembly which allows for leak testing before the unit leaves the factory. Zinc/chromate plated for rust protection.

BELLOWS Wall gauge is approximately 1/4". See page 5 for detailed information.

BELLOWS END CLOSURE — (steel) Permanently molded into the bellows (Except for styles 1T19L-7, 1T19L-11).

PISTON May be made of aluminum, steel, plastic or hard rubber. Held to the bellows by a bolt which screws into the bumper stud. For mounting, a long bolt may be used coming up through the mounting surface. Or, a short bolt may be used to attach the piston to the lower end closure and then use the threaded holes in the piston to secure the assembly to the mounting surface. (A piston long bolt is usually not included).

BUMPER STUD A permanent part of the bellows end closure (and bellows). It has two functions:

1. The optional rubber bumper snaps over the outside.
2. The inside is a threaded hole (see data sheets for thread dimension and depth) used to secure the piston to the bellows.

THREADED HOLE May be used for attachment to mounting surface. Not included in some pistons (See individual data sheets for specific part configuration.)

CRIMPED BEAD PLATE MOUNTING HARDWARE

CRIMPED BEAD PLATE AIR SPRINGS Use the blind nuts for attachment. This is accomplished by bringing bolts (two or four depending upon air spring size) through the

customer supplied mounting plate and tightening into the blind nut. If this bolt is too long, it may fracture the bottom out of the blind nut.

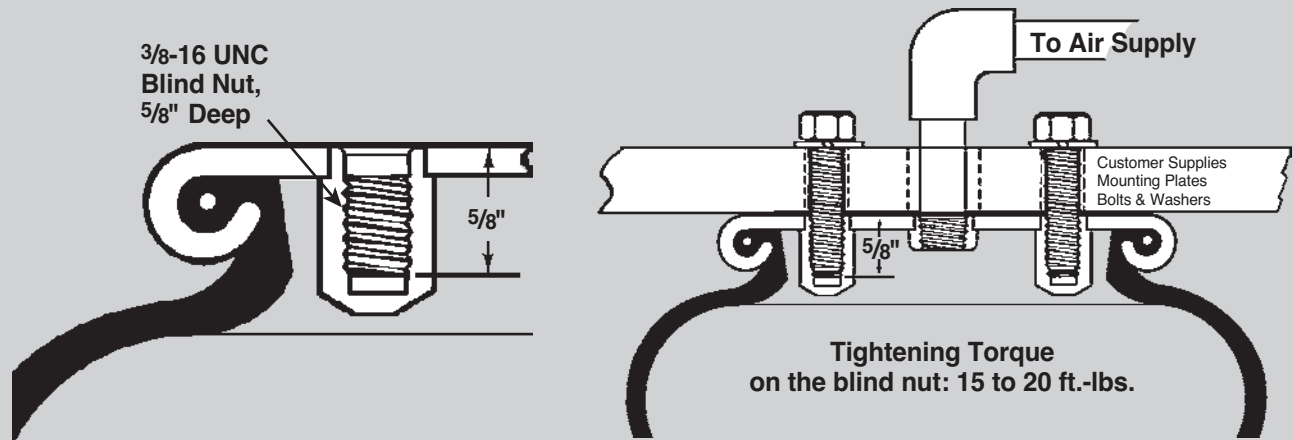

STUD ADAPTER

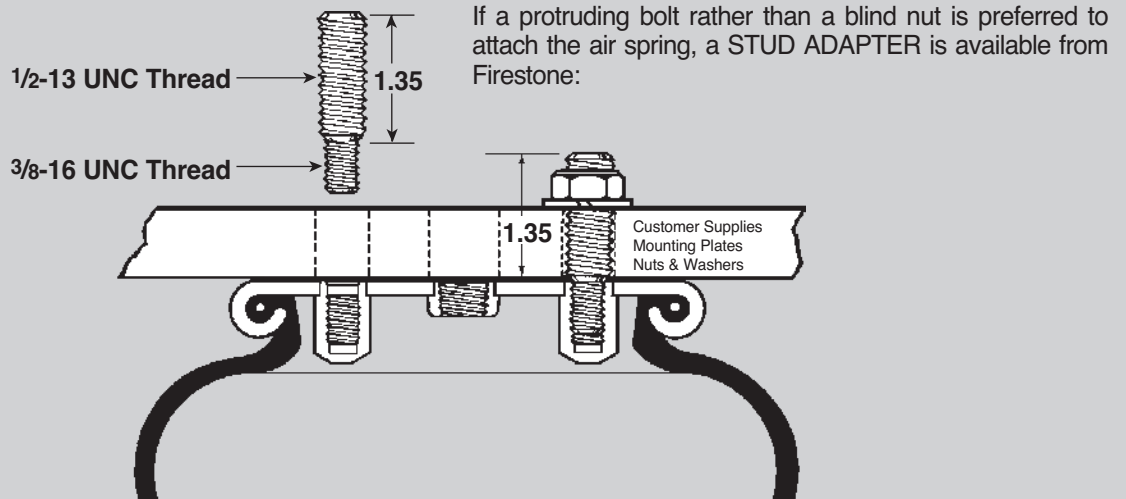

TANK VALVE One method for inflating air springs (primarily used in Airmount isolator applications) is with a tank valve: An air hose chuck is used (as inflating a

tire with an air line). Care must be taken to periodically check the pressure within the air spring, because air will slowly permeate through the rubber/fabric bellows (See page 25).

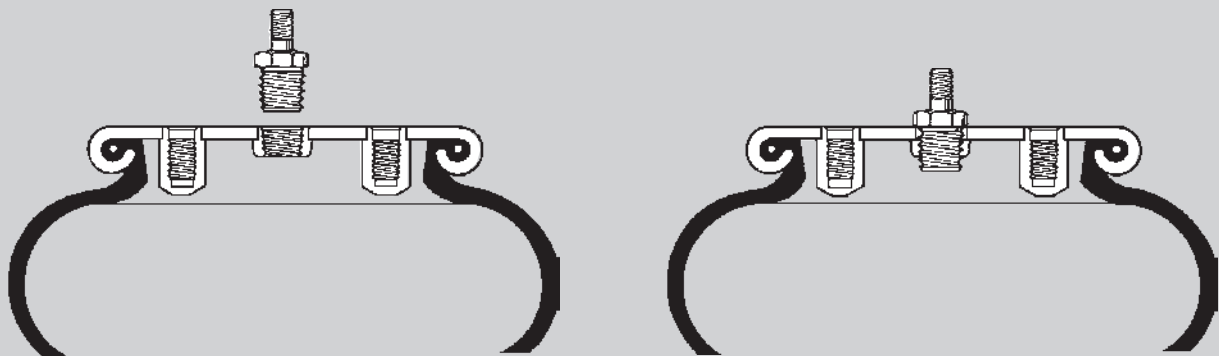

END CLOSURE OPTIONS

STEEL BEAD RINGS

CONVOLUTED AIR SPRINGS

(#22 is shown, with bead rings instead of crimped bead plates)

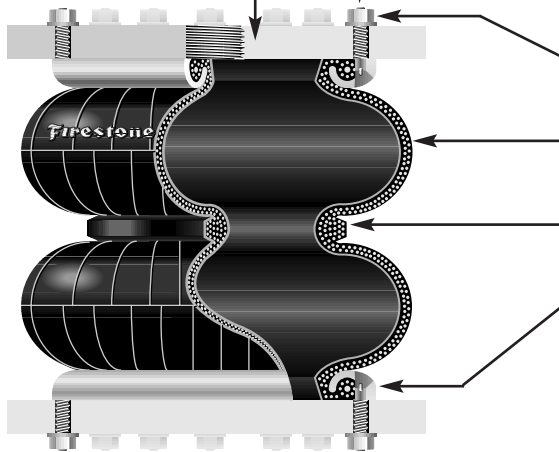

MOUNTING PLATE is not included. See page 10 for material, machining recommendations, and installation instructions.

BEAD RING BOLT May be one of three varieties. See page 10. Also refer to the data sheet order block on each individual part for bolt lengths.

NUTS AND LOCKWASHERS are included with the part. (Except for socket head type bead rings).

BELLOWS Wall gauge is approximately 1/4". See page 5 for detailed information.

GIRDLE HOOP Wire wound type shown, molded into the bellows.

BEAD RING, upper and lower. Countersunk steel type shown. See page 10. Also refer to the data sheet order block on each part for type and material. See the selection guide on page 32 for bolt circle diameter and number of bolts (each ring).

REVERSIBLE SLEEVE AIR SPRINGS

(1T15M-6 is shown, with a bead ring instead of a crimped bead plate)

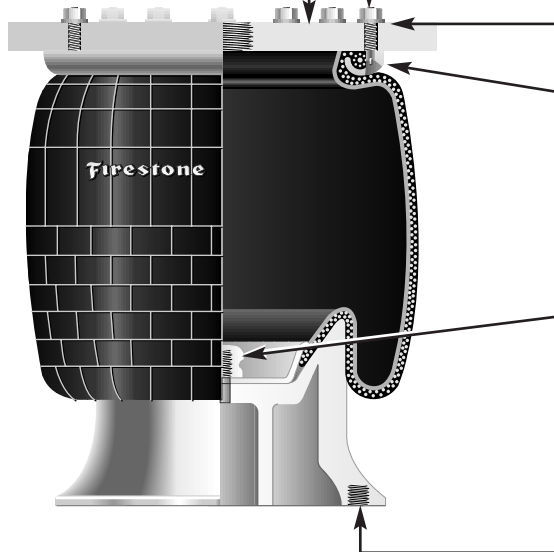

MOUNTING PLATE is not included. See page 10 for material, machining recommendations, and installation instructions.

BEAD RING BOLT May be one of three varieties. See below. Also refer to the data sheet order block on each individual part for bolt lengths.

NUTS AND LOCKWASHERS are included with the part. (Except for socket head type bead rings).

BEAD RING Countersunk steel type shown. See the selection guide on page 32 for bolt circle diameter and number of bolts (each ring).

BUMPER STUD A permanent part of the bellows end closure (and bellows). It has two functions:

1. The optional rubber bumper snaps over the outside (of it).
2. The inside is a threaded hole (see data sheets for thread dimension and depth) used to secure the piston to the bellows.

THREADED HOLE May be used for attachment to mounting surface. Not included in some pistons. (See individual data sheets for specific part configuration.)

END CLOSURE OPTIONS

LARGE PARTS WITH ALUMINUM BEAD RINGS

All of the parts that are shown with crimped bead plates are also available with bead rings. (Bead plates are not suitable for some applications.) Typical examples of where bead rings are often used follow:

1. Where parts are stacked to increase stroke (See page 16).
2. Where the air spring is being used as a boot or flexible connector (See page 29).
3. When used as an Airmount isolator with an auxiliary reservoir (See page 24).
4. When air must move in or out of the unit at an extremely fast rate (and a 3/4" NPT air inlet is too small).
5. When used with an internal shaft, to either guide the part or to pull (rather than push) a load.

CONVOLUTED AIR SPRINGS

(#203 is shown)

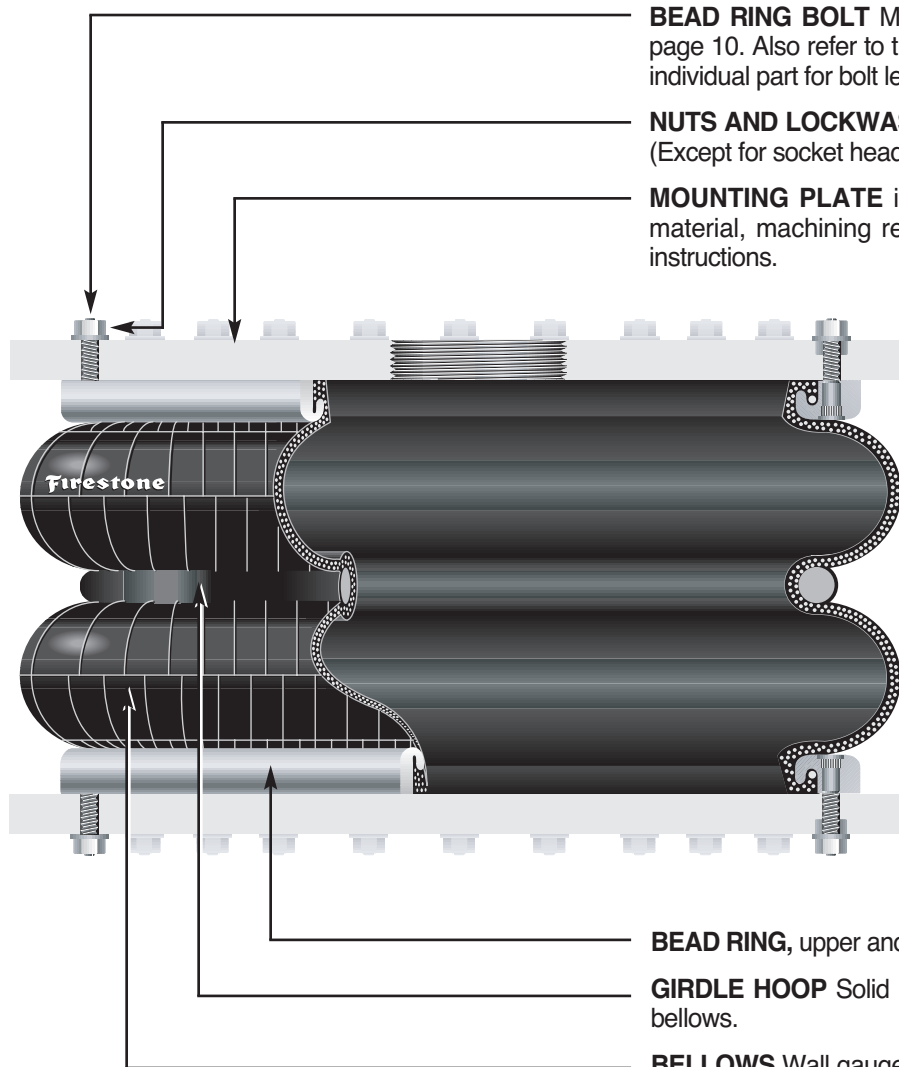

BEAD RING BOLT May be one of three varieties. See page 10. Also refer to the data sheet order block on each individual part for bolt lengths.

NUTS AND LOCKWASHERS are included with the part. (Except for socket head type bead rings).

MOUNTING PLATE is not included. See page 10 for material, machining recommendations, and installation instructions.

BEAD RING, upper and lower. (Aluminum)

GIRDLE HOOP Solid steel type shown, molded into the bellows.

BELLOWS Wall gauge is approximately 1/4". See page 5 for detailed information.

END CLOSURE OPTIONS

THE THREE TYPES OF BEAD RINGS

COUNTERSUNK STEEL BEAD RING	RIBBED NECK ALUMINUM BEAD RING	SOCKET HEAD ALUMINUM BEAD RING*
		
Standard Bolt Length (in.) 1 3/4	Standard Bolt Length (in.) 1 7/8	
Standard Effective Length (in.) 1.22	Standard Effective Length (in.) 1.28	
Standard Order Number (bolt only) WC1-358-3625	Standard Order Number (bolt only) WC1-358-3620	
Thread 5/16-24 UNF	Thread 3/8-24 UNF	
Tightening Torque (ft.-lbs.) 17 to 22	Tightening Torque (ft.-lbs.) 28 to 32	

BEAD RINGS CONTINUED

When using bead rings, THE CUSTOMER WILL NEED TO FABRICATE HIS OWN MOUNTING PLATES. Hot or cold rolled steel provides satisfactory mounting surfaces, with specific finishes of 250 microns, if machined in a circular fashion, and 32 microns when ground. The thickness of mounting plates depends upon the application. The plates must be strong enough and backed by structural members to prevent bowing (of the plates) when subjected to the forces or loads involved. The rubber bellows provides its own seal; therefore, 'O' rings or other sealants are not needed when installing the part.

INSTALLATION

Follow this technique for assembling a bead ring style bellows to the mounting plate:

- Insert the bolts into the bead ring (the bead rings have been previously attached to the bellows at the factory). The bolts will be pulled into place by the action of tightening the nuts.
- Slip all of the bolts (which are protruding through the bead ring) into the mating holes of the mounting plate and attach the lockwashers and nuts. FINGER TIGHTEN all nuts to produce a uniform gap between the bead ring and mounting plate all the way around.

- At this point, make certain that the bellows bead is properly seated under the bead ring.

PLEASE NOTE THAT UNIFORM SUCCESSIVE TIGHTENING OF THE NUTS IS IMPORTANT TO SEAT THE RUBBER BEAD PROPERLY TO THE MOUNTING PLATE FOR ITS FULL CIRCUMFERENCE.

Continue with the following sequence:

- Tighten all nuts one turn each, moving around the circle until continuous contact is made between the bead ring and mounting plate.
- Torque all nuts to the torque specifications shown on the page, going at least two complete turns around the bolt circle.

MATERIAL

Bead rings are supplied in either steel or aluminum. Both the bead ring material and type of ring are called out in the description section of the order block on each individual data page. Also, the bolt length (for the bolts supplied with that particular order number) is given.

WHERE A BEAD PLATE PART IS SHOWN AND THE BEAD RING ATTACHMENT IS PREFERRED, PLEASE REFER TO THE SELECTION GUIDE ON PAGE 32 FOR BOLT CIRCLE DIAMETERS AND NUMBER OF BOLTS (EACH RING).

END CLOSURE OPTIONS

LARGE PARTS WITH ROLLED PLATES

LARGE CONVOLUTED AIR SPRINGS

(#203 is shown, with rolled plates instead of bead rings)

The convoluted parts, with 17, 20, and 22 inch diameter, are shown with bead rings as standard. We have developed a method for permanently attaching plates to these larger sized Airstrokes (called rolled plate assembly). These parts may be an advantage over the bead ring parts in some cases, because installation is much easier (they attach the same way as the bead plate parts). When installing the rolled plate parts, a backup plate as large in diameter as the bead plate must be used. This plate should be a minimum of 1/2 inch thick.

Again, for the blind nut and air entrance locations of rolled plate parts (bead rings are shown as standard on the data pages), please refer to the selection guide on page 32. The static data chart on each individual part may be used for the rolled plate version; but, two modifications must be made:

1. Increase the minimum height by .70 inch.
2. Add .70 inch to the height (bottom axis) before reading loads.

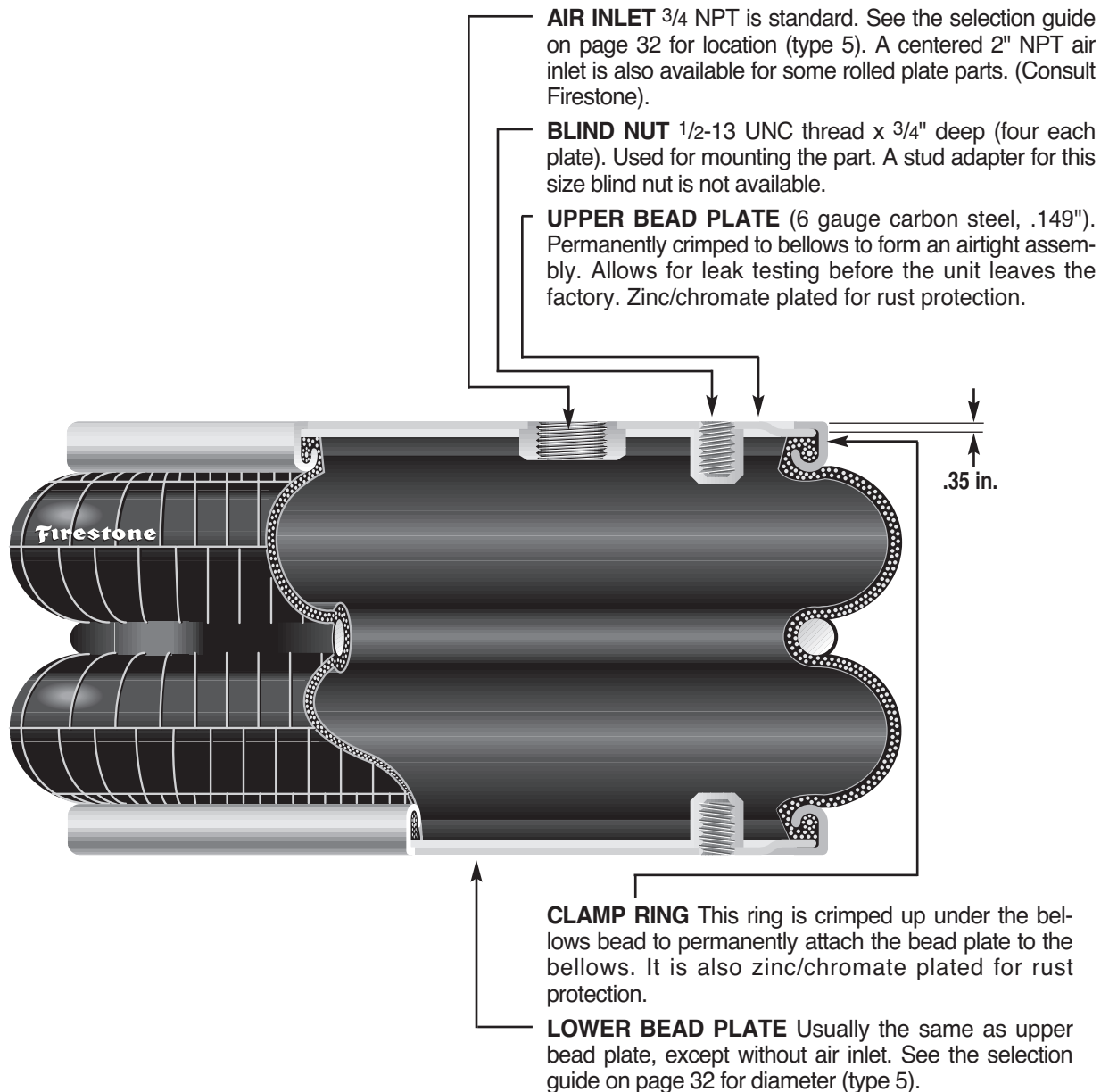

HOW TO USE THE STATIC DATA CHART

We also refer to this chart as the load/deflection (L/D) curve for an air spring. The force [1] is given on the right hand axis vs. the air spring height [2] as shown along the bottom axis; thus, load vs. deflection. The internal volume [3] is also given along the left hand axis, again vs. height [2]. It is called static data because the air spring is in a static, or non-moving, constant pressure condition. In almost all cases the static curves were run using a two ply bellows; however, *where a four ply bellows is available, use the two ply chart for it also.*

AIRSTROKE ACTUATION

The important considerations are minimum height [4] (3.0 inches) and maximum recommended height [5] (10.1 inches). Subtracting one from the other gives the stroke potential for this part (10.1 – 3.0 = 7.1 inches). As an actuator, the entire stroke may be used, or *any portion thereof.* Ignore recommended airmount design height [6] and the corresponding darkened line [7]. This height is important in using the air spring as an isolator (AIRMOUNT). It has nothing to do with the concern here of actuation. To determine the force at any given height, simply move up the height line to where it intersects any of the static pressure curves. Then move to the right and read from the force scale [1].

EXAMPLE: At 80 psig, what is the force using a #22 from 4.0 to 9.0 inches, or $9.0 - 4.0 = 5.0$ inch stroke? See [8] for force at 4.0 inches (7,180 #) and [9] for force at 9.0 inches (4,670 #). This example illustrates the primary difference between Firestone Airstrokes and conventional air cylinders. Air cylinders have a constant area for the pressure to work against, or constant effective area. *the effective area and force of an air spring changes as the height changes.* (There is one exception: notice the plateau section of reversible sleeve 1T type curves.)

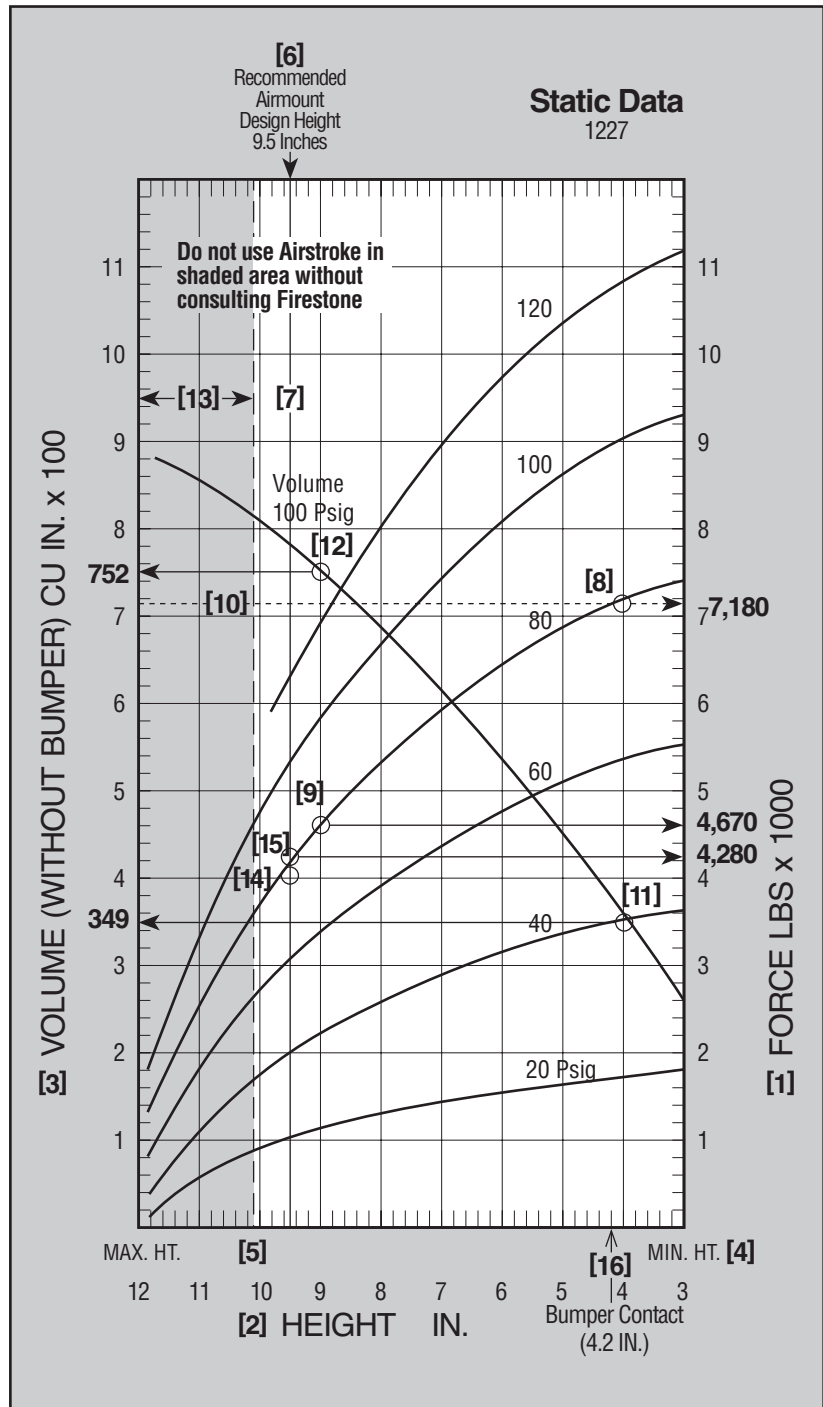

In the example the effective area of a #22, at 4.0 inches using the 80 psi curve, is:

$$\frac{7,180 \text{ lbs.}}{80 \text{ lbs/in}^2} = 89.8 \text{ in}^2$$

at 9.0 inches in height it is:

$$\frac{4,670 \text{ lbs.}}{80 \text{ lbs/in}^2} = 58.4 \text{ in}^2$$

An air cylinder with 89.8 in² of area would have an 80 psi curve as shown by dotted line [10].

The volume curve [3] may also be of importance:

- a. If one needs to know the amount of free air (then compressed by the compressor) to perform a desired operation.
- b. If the actuation must be completed quickly and calculations of flow through the air inlet (orifice) are required.

In each case above, the change in internal volume is required. Read up from the two heights involved to the intersecting point with the volume curve. Then move to the left and read from the volume scale. In the example at 4.0 a #22 (notice most volume curves are at 100 psig) has an internal volume of 349 in³ [11] and at 9.0 the volume is 752 in³ [12]. The change in volume is then 752 in³ – 349 in³, or 403 in³. The volume at minimum height (349 in³) would not be subtracted if exhausting the air spring to atmospheric pressure.

Notice the shaded area [13]. We do not recommend that an air spring be used at heights extending into this section. The “beginning of the shaded area” for a #22 is at 101 inches [5].

SEE PAGE 15 FOR A MORE DETAILED DISCUSSION OF ACTUATION.

AIRMOUNT ISOLATION

Because of lateral stability considerations (see page 23 for more details) we recommend that each air spring be used at a *specific height* when used as an *isolator*. This specific height is called the “Airmount design height” [6]. The vertical line running through this height [7] is darkened so that it is easy to see where it intersects the static curves for load readings.

EXAMPLE: Support a 4,100 pound load with an air spring. Would a #22 be appropriate, and if so, at what height? The height isn’t much of a problem, as this part SHOULD BE USED AT 9.5 INCHES. Simply move up the darkened line to where it intersects 4,100 lbs [14]. That point falls between the 80 and 60 psig curves. Exactly what pressure would be required? Use the formula:

$$\text{Effective Area} = \frac{\text{Load (lbs.)}}{\text{Pressure (lbs/in}^2\text{)}}$$

Determine the effective area at 9.5 inches (using the 80 psig curve, since 80 psig would be closer to our exact pressure than 60 psig), or:

$$\text{Effective Area} = \frac{4,280 \text{ lbs. [15]}}{80 \text{ lbs/in}^2} = 53.5 \text{ in}^2$$

Then divide the actual load by the effective area:

$$\frac{4,100 \text{ lbs.}}{53.5 \text{ in}^2} = 76.6 \text{ PSIG}$$

The pressure required to support 4,100 lbs. with a #22 at a design height of 9.5 inches is therefore 76.6 PSIG.

Please note that the static data can be converted to dynamic data (the air spring is in motion) by applying the formulas that are presented in the Airmount isolation section on page 22.

SEE PAGE 21 FOR A MORE DETAILED DISCUSSION OF VIBRATION ISOLATION.

INTERNAL RUBBER BUMPERS

Some parts are available with internal rubber bumpers. Where a bumper is available, it is shown as a dotted line in the cross sectional view of the air spring. Additionally, please note that:

1. the minimum height is increased to the “bumper contact” point [16] (this reduces the total available stroke somewhat, by 4.2 – 3.0 = 12 inches in our #22 example), and
2. the order block contains the proper ordering numbers for parts with bumpers.

BASIC PARAMETERS APPLICABLE TO BOTH AIRSTROKE™ ACTUATORS AND AIRMOUNT™ ISOLATORS

MEDIA

Air springs are designed for use with compressed air. Nitrogen is also acceptable. Air springs may be filled with water or water-glycol (automotive antifreeze) solutions. If water is to be used, rust inhibitors should be added to protect the end closures. Two reasons for liquid filling an air spring are:

1. To reduce the internal volume of air (and therefore, *increase* the natural frequency of the air spring) and,
2. To use a media which is incompressible. Accurate positioning would be one reason to do this.

Petroleum base fluids (most hydraulic oils fall into this category) are NOT RECOMMENDED. Moderately lubricated air will not harm the bellows.

PRESSURE

1. 100 PSIG MAXIMUM FOR 2 PLY.
2. 175 PSIG MAXIMUM FOR HIGH STRENGTH.

We recommend that there be a minimum three times safety factor between maximum internal air pressure and burst pressure. So, as an example, if 100 psig is required, the burst should be at 300 psig or greater. For convoluted air springs, the burst pressure decreases as height increases. Therefore, the determining factors are twofold: What is the maximum height into extension and what is the internal pressure at that point? Please see the Airstroke Inflation Pressure Chart (for single, double, and triple convoluted air springs) on page 17 for specific pressure vs. height information.

For AIRMOUNT applications (where the part is used at a height very close to the shaded area), it is best to stay within 100 psig maximum for a two ply, and 150 psig maximum for a four ply or high strength cord air spring.

STORAGE

The best storage environment is a dark, dry area at normal room temperature.

TEMPERATURE

1. **STANDARD BELLOWS.** Our standard industrial air springs should be limited to use in the range:
– 35° F to + 135° F.

2. **ALL NATURAL RUBBER (LOW TEMPERATURE COMPOUND).** A few of our industrial air springs are available in all natural rubber construction. This increases the acceptable cold or low end of the scale to – 65° F. The range then becomes – 65° F to +135° F.

3. **EPICHLOROHYDRIN (HIGH TEMPERATURE COMPOUND).** Most convoluted parts are available in this material. The operating temperature range for it is: 0° F to 225° F. Additionally, Epichlorohydrin has very good oil resistance. ALL EPICHLOROHYDRIN APPLICATIONS MUST BE APPROVED BY FIRESTONE. For more information on Epichlorohydrin (also known as Herclor), ask for Technigram number 111.

4. **NEOPRENE (HIGH TEMPERATURE COMPOUND).** Neoprene is more resistant to damage from oil. For this reason, Firestone Neoprene has been used as the inside layer in two configurations to reduce the hazard of having oil in the pneumatic plumbing system. The third configuration includes an outer layer of Firestone Neoprene for applications that expose the exterior of the air spring to an oil environment. In addition, Firestone Neoprene is able to withstand higher temperatures than natural rubber (-35° to +165° F).

CONTAMINATES

Shielding should be used to protect the bellows from exposure to hot metal, sand, petroleum base fluids, acids, etc. Please consult Firestone if you wish to know how the bellows will withstand a specific contaminant (For liquids such as acids, it is important to know both concentration and temperature).

WARNING

DO NOT INFLATE ASSEMBLY WHEN IT IS UNRESTRICTED. ASSEMBLY MUST BE RESTRICTED BY SUSPENSION OR OTHER ADEQUATE STRUCTURE. DO NOT INFLATE BEYOND PRESSURES RECOMMENDED IN DESIGN LITERATURE (CONTACT FIRESTONE FOR INFORMATION). IMPROPER USE OR OVERINFLATION MAY CAUSE ASSEMBLY TO BURST CAUSING PROPERTY DAMAGE OR SEVERE PERSONAL INJURY.

AIRSTROKE ACTUATION

SELECTION

1. Refer to the selection guide on page 32 for Airstroke force and stroke capabilities. After your list of possibilities has been reduced to one or two air springs, then turn to the individual data page for more detailed information on those parts.
2. **STROKE:** The maximum STROKE CAPABILITY is the difference between the height corresponding to the “start of the shaded area” minus the minimum height. This entire stroke, or any portion thereof, may be used. If an internal rubber bumper is required, please note that the minimum height is increased, and therefore, the total stroke is decreased.
3. **FORCE:** Read the forces directly from the static data chart, or, use the force table located under the chart. Notice that the force generally decreases as height increases. This feature is discussed in detail on page 12 in the section entitled “How to Use the Static Data Chart.”
4. **SELECT THE END CLOSURES AND AIR INLET SIZE:** Most Airstroke actuators are available with permanently attached plates or bead ring attachments. If an alternate end closure option is available, it is so stated under the cross sectional view of the part. Please refer to page 6 for a detailed discussion of end closure options.

DOWN AND UP STOPS

Positive stops in both directions (compression and extension) should always be used with Airstroke actuators .

1. In COMPRESSION, the minimum height shown for each air spring is at, or slightly above the PINCH POINT of the bellows. Here is a #22 shown in the collapsed or “pinch point” condition:

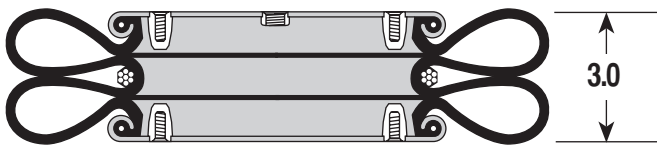

The bellows can be damaged if allowed to constantly bottom out as shown above; therefore, a downstop is required to prevent this. An external downstop can be something as simple as a steel block and should be sized at or slightly greater than the minimum height of the Airstroke. In our #22 example, the block would need to be at least 3.0 inches high. If an external downstop cannot be used, many parts are available with internal rubber bumpers (shown as a dotted line in the cross-sectional view of the air spring where available).

2. In EXTENSION, an upstop is required to prevent the air spring from overextending at heights into the shaded area of the graph. The reasons for this are twofold: **a)** the life of the bellows may be reduced and **b)** the crimp may open up, allowing the bellows bead to blow out of the metal end closure. There are many ways to design-in an upstop, including
 - a. a chain,
 - b. a cable,
 - c. contacting a metal stop, etc.

RETURN

An Airstroke actuator is a *single acting* device. To return the Airstroke to its minimum height (for another cycle or stroke), some return force must be used. Gravity acting on the load may be all that's required. The force to collapse the convoluted type Airstrokes to minimum height is given in the order block section for each part. If the load is not sufficient, then a second Airstroke or coil spring may be required.

GUIDING

An Airstroke follows the path of least resistance; therefore, the actuator should be guided in most instances. This is often easily accomplished in the mounting geometry.

ANGULAR CAPABILITY

An Airstroke actuator can stroke through an arc (without a clevis). Angular motion of up to 30 degrees is possible. When using an actuator with the mounting plates at an angle to each other, observe the following:

- a. Measure force at the height between the plate centers.
- b. Measure maximum height at the side separated the furthest.
- c. Measure minimum height at the side collapsed the most.

Angular Capability continued

These measurements must fall within the guide lines for that particular part. Consider style #22 in the following scissors arrangement:

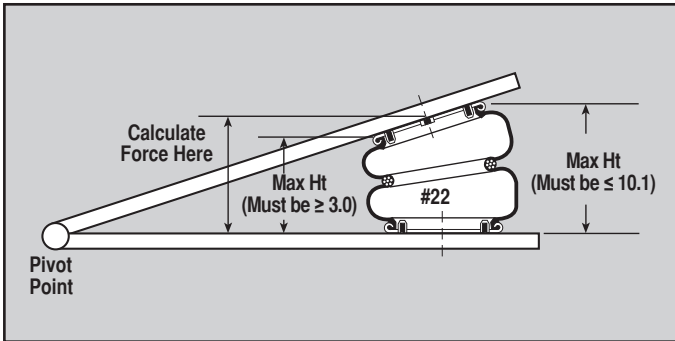

Reversible sleeve Type 1T parts may also stroke through an arc. In this case, care must be taken to prevent the bellows from rubbing (internally) against itself where it rolls over the piston:

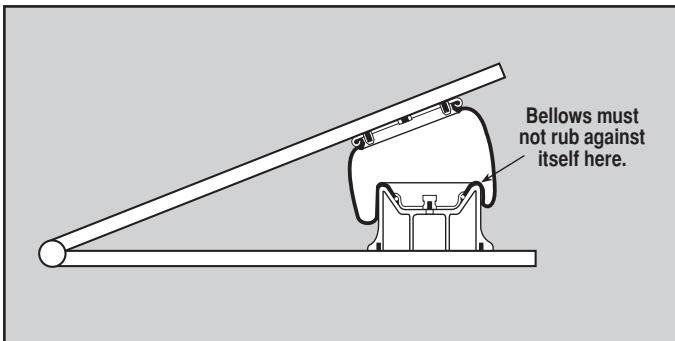

HORIZONTAL MISALIGNMENT

The upper and lower bead plate centers (or mounting plate centers in the case of a bead ring type attachment) may be out of line somewhat without injury to the bellows. Our "rule of thumb" for convoluted type Airstrokes is one inch misalignment allowed per convolution. So, a single convoluted air spring may be out of line by as much as 1 inch, a double by 2 inches, and a triple convoluted air spring by 3 inches.

DESIGN ENVELOPE

Adequate clearance should be provided around the Airstroke to prevent puncturing or rubbing of the bellows. The maximum diameter @ 100 psig for each Airstroke (bellows) is located just above the cross-sectional view of the air spring.

STACKING

It is permissible to stack Airstrokes (one on top of another) to increase stroke; however, the center plate (or plates) connecting the two or more Airstrokes MUST BE GUIDED.

Please note that the air spring forces are *not* additive in this configuration. A method for guiding, which also illustrates one center ring concept for mounting the two parts together at the middle, is illustrated below:

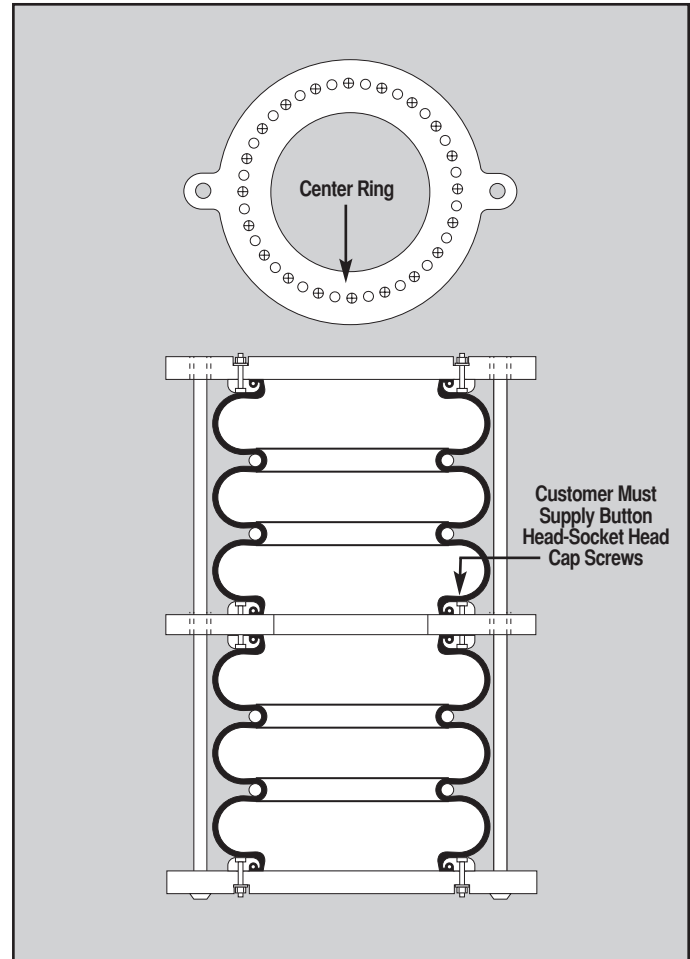

FAIL SAFE DEVICES

Some applications require the use of fail safe mechanisms (such as a mechanical lock-out on a scissors lift) to prevent damage or injury in the event of an air system failure.

VACUUM

An Airstroke can withstand a small amount of vacuum without injury to the bellows. The maximum amount of acceptable vacuum is dependent upon the bellows' size, the height in use, and whether it is a two ply or high strength (fabric) air spring. (A high strength Airstroke bellows has a "stiffer" wall than a two ply; therefore, it is less susceptible to dimpling and deformation inward). It is generally best to use only single convoluted air springs under vacuum.

An Airstroke Design Parameter Worksheet can be found on page 105.

AIRSTROKE™ ACTUATOR PROBLEM SOLVERS

GATE VALVE OPERATOR

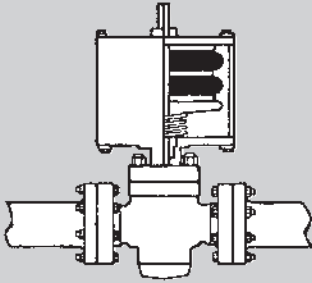

GLUING PRESS



WEB TENSIONING DEVICE

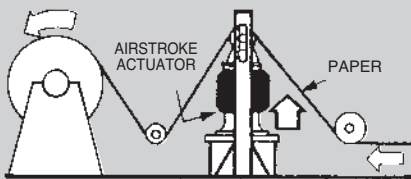

DIE STRIPPER

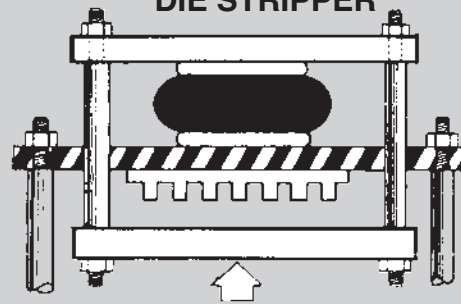

KNIFE SPRING ACTUATOR

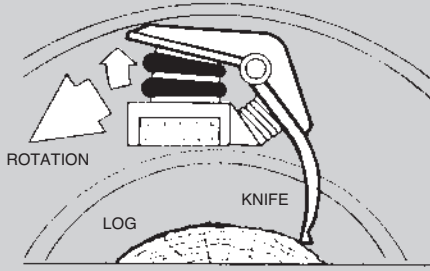

QUENCH TANK ACTUATOR

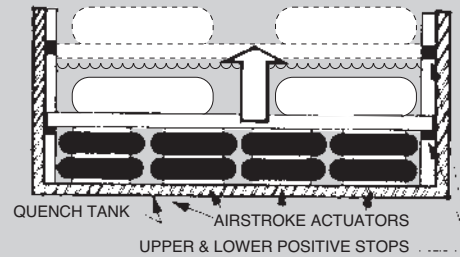

PAPER SIZING PRESS

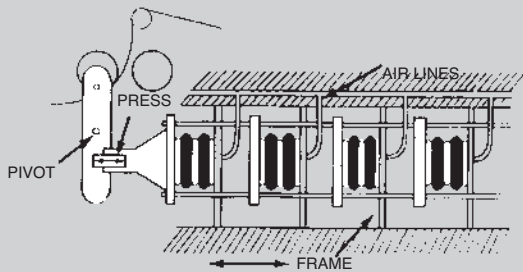

PICKLING TANK ACTUATOR

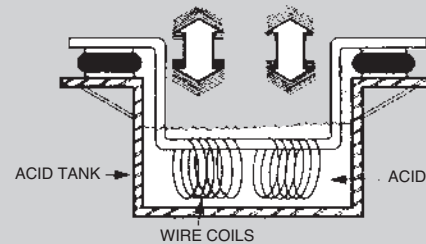

QUICK LOCK DEVICE

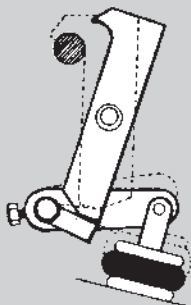

PRESSURE ROLL FOR CALENDER



AIRSTROKE™ ACTUATOR PROBLEM SOLVERS

MISSILE ASSEMBLY FIXTURE

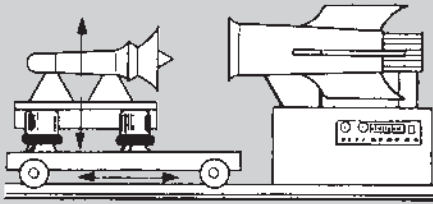

CORE STRAIGHTENER

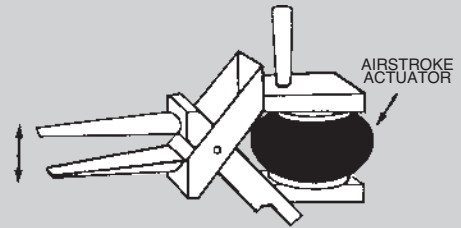

BELT TAKE UP



ROLLER FRICTION BRAKE

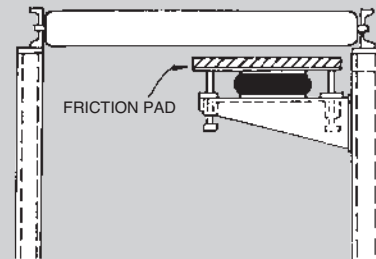

PIPE INDEXING THREADING

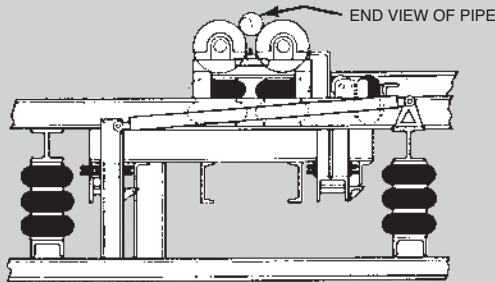

OSCILLATING DOCTOR FOR PAPER CALENDER ROLL

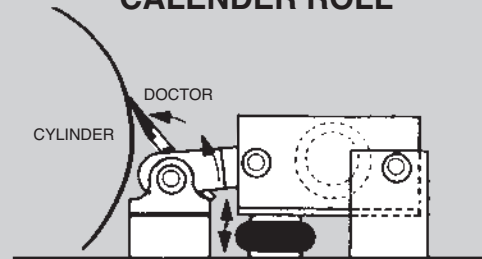

FORMING PRESS

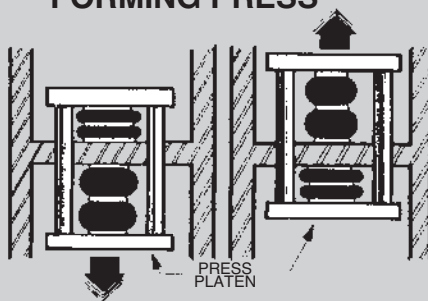

CABLE TENSIONING DEVICE

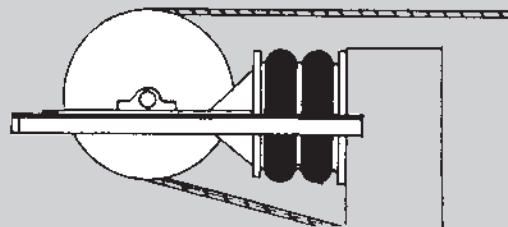

BAG FLATTENER

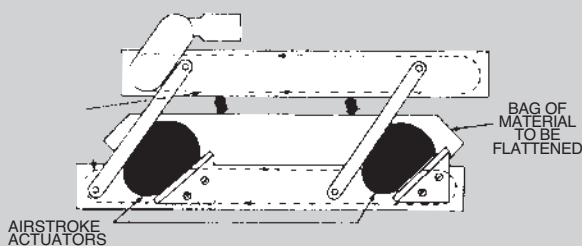

TORSIONAL FRICTION BRAKE

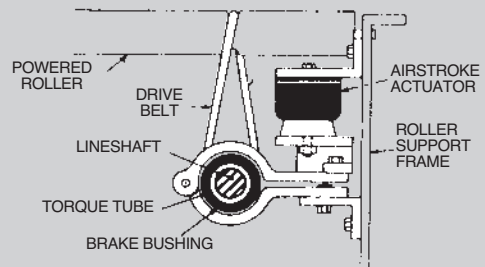

AIRSTROKE™ ACTUATOR PROBLEM SOLVERS

HINGED GATE

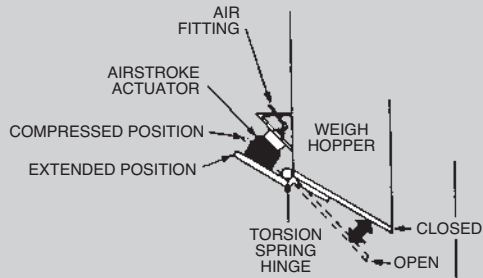

HOT FOIL STAMPING PRESS

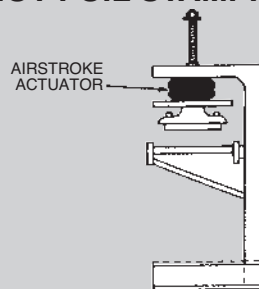

ACTUATED HEAVY DUTY SEALER

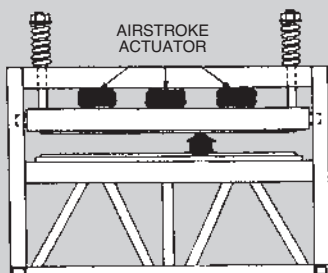

PIVOTED CLAMPING DEVICE

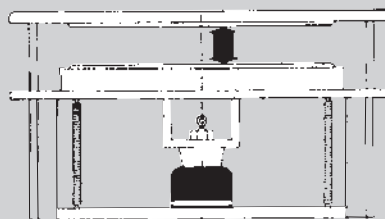

AIRSTROKE ACTUATED ROLLER STOP

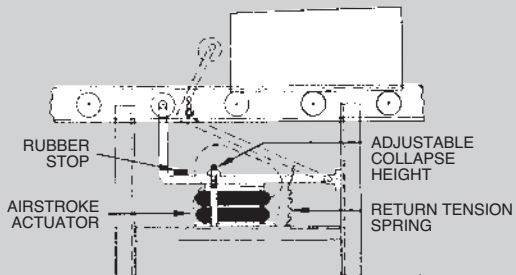

HINGED ACTUATED GRAVITY GATE

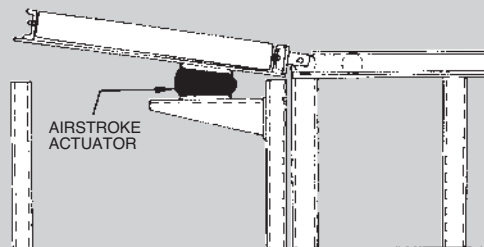

VERTICAL ACTUATED DRIVE TABLE

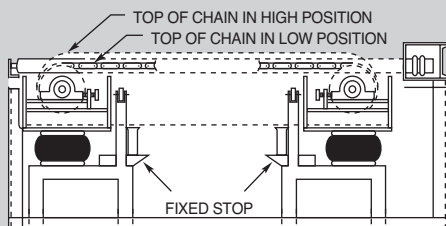

SCISSOR LIFT

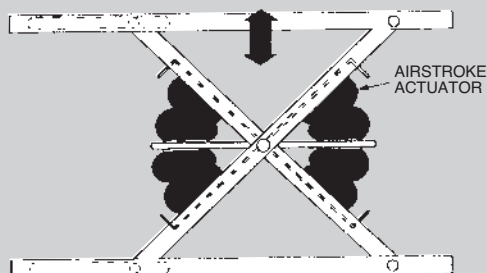

CASE PACKER

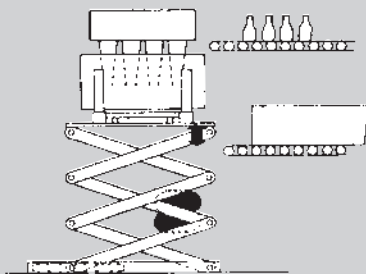

CONVEYOR TRANSFER ACTUATOR

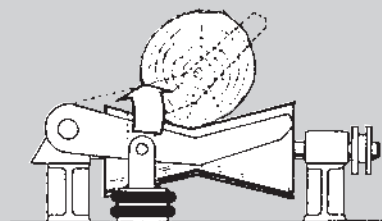

AIRMOUNT™ VIBRATION ISOLATION

SELECTION AND ISOLATION FORMULA

Refer to the selection guide on page 33 for Airmount load and isolation capabilities. Follow this procedure:

1. LOAD CAPACITY

Select one or two Airmounts that can support the load at each mounting point. It is normally best to design for pressures in the 60 to 80 psig range. Consider only the 1M1A-0 and the single and double convoluted types at first. Please notice that in the range of 210 to 63,890 pounds you will, in most cases, find both a single and double convoluted style part which will support the load.

2. DETERMINE ISOLATION EFFECTIVENESS

Select the disturbing frequency that is closest to the actual forced frequency (400, 800, or 1500 cpm). Then check the percentage of isolation for the parts that were selected in 1 above.

3. DETERMINE DESIGN HEIGHT

THE AIR SPRING SHOULD BE USED AT THE DESIGN HEIGHT GIVEN. The double convoluted part is used at a design height somewhat higher than its single convolution equivalent. Make sure that the design height falls within the height restrictions. Also, the double convoluted part will show a higher percentage of isolation (less transmitted vibration) than the single convoluted air spring. The reason for this is that the double convoluted part has a greater internal volume of air than the single convoluted version of the same size. At disturbing frequencies in the 400 to 800 cpm range, the double convoluted part is a significantly better vibration isolator than the single convoluted part. At disturbing frequencies of 800 to 1500 cpm, the gap closes considerably. At frequencies of 1500 cpm and above, the difference is negligible.

4. DETERMINE EXACT INTERNAL PRESSURE AND ISOLATION EFFECTIVENESS

The chances are that your specific vibration problem does not fall neatly into the load and disturbing frequency criteria as presented in the selection guide.

Therefore, once a preliminary part selection has been made, turn to the individual data page for that part in order to determine the specific internal pressure required and the percentage of isolation attainable.

CONSIDER THIS EXAMPLE:

Isolate a vibrating screen which weighs a total of 16,400 pounds, preferably with *one* isolator at each corner. The vibrating mechanism is rotating at a speed of 850 rpm (cpm) with a total stroke of $\frac{5}{16}$ inch.

- a. Determine the load at each mounting point:

$$\frac{16,400}{4} = 4,100 \text{ lbs.}$$

Scan down the 80 psig load column in the selection guide. It appears that either a #19 or a #22 will support the load at a pressure between 60 and 80 psig.

- b. Determine Isolation Effectiveness.

Read the % of Isolation at 800 cpm for the #19 and #22 (since 800 is closest to our machine speed of 850 cpm). A #19 is at 96.0% and a #22 is at 98.2%. Looking at isolation effectiveness in terms of % TRANSMISSION, the #19 will transmit $100 - 96.0$, or 4.0% of the vibrations. A #22 will transmit $100 - 98.2$, or 1.8% of the vibrations. So, even though there does not seem to be much difference between 96.0% and 98.2% isolation, the #22 is in fact a better isolator by approximately a factor of two when comparing transmitted vibration.

- c. Determine Design Height.

Let's say we have chosen the #22 because 96.0% isolation for a #19 is considered to be too low. A #22 should be used at 9.5 inches as shown in the second column on page 33.

- d. Determine Exact Internal Pressure and Isolation Percentage.

Turn to page 61 for detailed information on the #22.

- a) What exact pressure will be required to support the load of 4,100 lbs? Refer to the information in the block entitled "Dynamic Characteristics at 9.5 in Design Height."

$$\frac{4,280 \text{ lbs.}}{80 \text{ lbs/in}^2} = 53.5 \text{ in}^2 = \text{effective area @ 9.5 inches @ 80 psig}$$

Divide the actual load by the effective area:

$$\frac{4,100 \text{ lbs.}}{53.5 \text{ in}^2} = \underline{76.6} \text{ psig required to support 4,100 lbs. at 9.5 inches}$$

AIRMOUNT™ VIBRATION ISOLATION

b) What exact isolation will be attained?

Use the formula:

$$\% \text{ Transmission} = \frac{100}{\left(\frac{f_f}{f_n}\right)^2 - 1}$$

Where: f_f = Forced Frequency
 f_n = Natural Frequency

The forced frequency is 850 cpm. Read the natural frequency from the line at the load and pressure closest to the actual situation, or 106 CPM (@ 80 psig and 4,280 lbs.):

$$\% \text{ Transmission} = \frac{100}{\left(\frac{850}{106}\right)^2 - 1}$$

% Transmission = 1.6%
 % Isolation = 100 - % Transmission
 % Isolation = 100 - 1.6
 % Isolation = 98.4%

Notice that the natural frequency of an Airmount changes only slightly with variations in pressure and load. Therefore, when working at pressures other than 40, 60, 80, or 100 psig, % isolation can be calculated quite accurately using the "closest" natural frequency and the formula above.

DYNAMIC SPRING RATE FORMULA

Spring rate is a different matter. Unlike most conventional springs, the rate of an Airmount is not constant. It is a function of the change in effective area, volume, and pressure from design height. To determine the rate of an Airmount, use the following formula:

$$K = \frac{\left[[P_g + 14.7] \left[A_c \left(\frac{V_1}{V_d} \right)^{1.38} - A_e \left(\frac{V_1}{V_e} \right)^{1.38} \right] - 14.7(A_c - A_e) \right]}{1 \text{ inch}} \text{ lbs}$$

WHERE:

- K = Vertical Spring Rate in lbs./inch
- P_g = Gauge Pressure at design height $\left(\frac{\text{lbs}}{\text{in}^2}\right)$
- A_c = Effective Area at 1/2 inch below design height (in^2)
- A_e = Effective Area at 1/2 inch above design height (in^2)
- V_1 = Internal Volume at design height (in^3)
- V_c = Internal Volume at 1/2 inch below design height (in^3)
- V_e = Internal Volume at 1/2 inch above design height (in^3)

Consider the same #22 example: What is the vertical spring rate with a load of 4,100 pounds at a design height of 9.5 inches? Refer to the static data chart on page 62. Again, our "closest" pressure is 80 psig, so we'll need to read the appropriate data from the 80 psig curve.

The 80 psig information at 1/2 inch above design height would fall at the 10.0 inch height line, and 1/2 inch below design height would fall at the 9.0 inch height line. (In this example, we can read loads from the force table). The information at design height is located in the "Dynamic Characteristics Block." So,

K = Unknown
 $P_g = 76.6$ psig (see page 13)
 $A_c = 58.4 \text{ in}^2 = \left(\frac{4,670 \text{ lbs.}}{80 \text{ lbs/in}^2}\right)$
 $A_e = 47.6 \text{ in}^2 = \left(\frac{3,810 \text{ lbs.}}{80 \text{ lbs/in}^2}\right)$

$V_1 = 782 \text{ in}^3$
 $V_c = 752 \text{ in}^3$
 $V_e = 809 \text{ in}^3$

$$K = \frac{\left[[76.6 + 14.7] \left[58.4 \left(\frac{782}{752} \right)^{1.38} - 47.6 \left(\frac{782}{809} \right)^{1.38} \right] - 14.7(58.4 - 47.6) \right]}{1 \text{ inch}} \text{ lbs}$$

$$K = \frac{\left[[76.6 + 14.7] \left[58.4 \left(\frac{782}{752} \right)^{1.38} - 47.6 \left(\frac{782}{809} \right)^{1.38} \right] - 14.7(58.4 - 47.6) \right]}{1 \text{ inch}}$$

K = 1,324 lbs/inch

NATURAL FREQUENCY FORMULA

Once the spring rate is determined, calculate the Airmount natural frequency (for an *undamped* system) as follows:

$$f_n = 188 \sqrt{\frac{K}{L}}$$

Where:

- f_n = Natural Frequency in cycles per minute (cpm)
- K = Rate (lbs/inch)
- L = Load (pounds)

in our example:

$$f_n = 188 \sqrt{\frac{1,324}{4,100}}$$

$f_n = 106.8$ cpm

AIRMOUNT™ VIBRATION ISOLATION

Up to this point, only the weight and disturbing frequency have been discussed. THERE ARE MANY OTHER IMPORTANT CONSIDERATIONS:

CENTER OF GRAVITY

An Airmount isolation system is inherently soft (easily deflected); therefore, precautions must be taken to insure that the system is stable. First, consider the location of the center of gravity (c.g.). Ideally, the Airmounts should be located on the same plane (parallel to the ground) as the center of gravity. Where this is not possible, follow this guideline: The distance between the most narrow mounting points should be at least twice the height of the center of gravity.



In the above example, the most narrow distance between two Airmounts is 46 inches. The height to the c.g. is 48 inches; therefore, this system does not meet our guideline. Two possible solutions would be:

1. Increase the base dimensions to meet our guideline by increasing both the width and length to at least 48 x 2 or 96 inches.
2. Locate the Airmounts at the c.g. as shown above (in the next column).

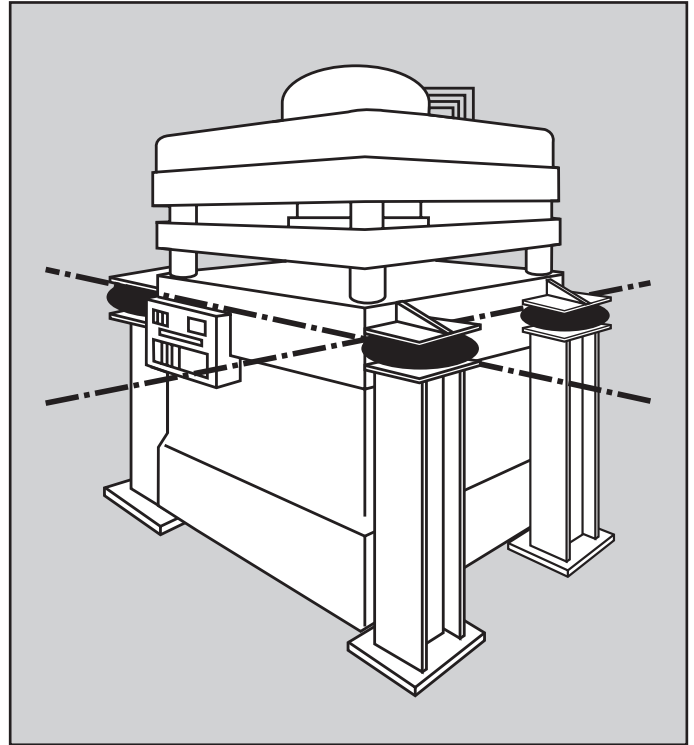

LATERAL RATES AND STABILITY

Single and double convoluted air springs **SHOULD BE USED AT THE DESIGN HEIGHTS GIVEN**, because that is the point of maximum lateral rate or stability. The lateral rate *decreases* as the Airmount height *decreases*. Consider a #22 again at 80 psig:

Height	Lateral Rate	Vertical Rate
9.5 inch (design height)	325 lbs/in	1,373 lb/in
8.5 inch	212 lbs	—
7.5 inch	Unstable	—

Notice that the #22 becomes unstable in the horizontal or lateral direction when moving down only two inches from design height.

AIRMOUNT™ VIBRATION ISOLATION

At design height and without an auxiliary reservoir, the single and double convoluted parts follow this pattern; i.e., the lateral rate varies from $1/5$ to $1/2$ of the vertical rate (only the larger high strength parts get as high as $1/2$). Notice the #22 is approximately $1/4 \left(\frac{325}{1,373} \right)$. Going back to the original example of a vibrating screen which weighs 16,400 lbs. mounted on four #22's (@ 9.5 inches), a side load of 1,300 pounds (325×4) would deflect the entire suspended mass by one inch.

TRIPLE CONVOLUTED AND REVERSIBLE SLEEVE TYPE PARTS

Both of these types are unstable laterally (except for the 1M1A). Due to low natural frequencies, both can be excellent isolators; however, do not use these two types as Airmount isolators without consulting Firestone (for special guidelines and precautions).

DESIGN ENVELOPE

Adequate clearance should be provided around the Airmount to prevent puncturing or rubbing of the bellows. The maximum diameter @ 100 psig for each Airmount (bellows) is shown just above the cross sectional view of the air spring.

SAFETY STOPS

It is normally recommended that positive stops be installed *in all directions*; i.e., into compression, extension, and laterally. Positioning of the vertical stops depends upon the amplitude of movement, both during normal operation and startup and shutdown. A good "rule of thumb" is $\pm 1/2$ inch from design height for vertical stops and also $\pm 1/2$ inch (horizontally) for lateral stops.

INITIAL INSTALLATION

NEVER use Airmounts to lift equipment into place, due to the lateral instability at lower air spring heights as discussed previously. Equipment should be rested on stops set *slightly* below design height and raised into position for isolation.

STARTUP AND SHUTDOWN/ RESONANCE AND AMPLIFICATION

Resonance is the condition where the forced frequency of the vibrating system is at the natural frequency of the suspension. When this happens, AMPLIFICATION of movement occurs. Going back to our vibrating screen example again, if the normal stroke is $5/16$ of an inch, during startup and shutdown (as the machine goes through resonance), the amplitude of movement will be multiplied somewhat. So, while the machine is building up to speed and slowing down, the stroke may be amplified in the range of $1/2$ to $1 1/2$ inches. The longer the machine takes to go through resonance (to build up to, or slow down from full operating speed), the larger the amplitude of movement.

ISOLATING AN UNBALANCED MASS

The primary concern in this case is the amplitude of movement. It is dependent on:

- 1) The ratio of the unbalanced moving mass to the total suspended mass, and
- 2) The ratio of the speed of the unbalanced moving mass (forced frequency) to the natural frequency of the Airmounts.

The addition of damping to the isolation system (shock absorbers) will reduce the large amplitude of movement experienced during resonance.

If the amplitude of movement is too great, one possible solution would be to add an inertia base in order to increase the ratio of the total suspended mass to the moving unbalanced mass. A good "rule of thumb" is 10:1, respectively.

LOW PRESSURE OPERATION

The lateral rate of a single and double convoluted style Airmount *decreases* with decreasing internal air pressure (becomes unstable). Consult Firestone if you plan on operating an Airmount at less than 40 psig.

EFFECT OF AN AUXILIARY RESERVOIR

There is a direct relationship between natural frequency and isolation effectiveness. Generally, the lower the natural frequency, the better the isolator (or higher percentage of isolation). As previously mentioned, a double convoluted Airmount has a lower natural frequency than a single convoluted type (of the same size) because it has more internal air volume. We can use this principle to lower the natural frequency of an air spring by adding an auxiliary reservoir (pressure vessel) externally to the Airmount. This effectively increases the air spring volume and reduces its natural frequency.

In order for the reservoir to work properly, there must be a free flow of air between the Airmount and reservoir. Therefore, it should be mounted as close as possible to the Airmount. Additionally, a bead ring attachment is the best end closure choice as the hole in the upper mounting plate can be sized as large as the inside diameter of the bellows (at the top). A $3/4$ " NPT air inlet will restrict the flow of air somewhat, but can be used as long as it is understood that there is some throttling effect.

Going back to the #22 example, an auxiliary reservoir of three times the internal volume of the air spring at design height (approximately 10 gallons) will reduce the natural frequency from 106.8 cpm to 90.2 cpm. The spring rate also decreases, from 1,324 lbs./inch to 944 lbs./inch.

AIRMOUNT™ VIBRATION ISOLATION

DAMPING

Damping is defined as the ratio: $\frac{C}{C_c}$

WHERE: C = System Damping

C_c = Critical Damping

The damping ratio inherent in an Airmount is in the order of .03. This damping number is so small that the formulas presented in this section assume it to be zero.

PLUMBING SYSTEMS

There are three basic ways of controlling an air suspended isolation system:

1. Tank Valve System With a tank valve in each Airmount, each air spring is then inflated individually. The pressure in each must be checked periodically, because air will permeate through the bellows.

For an idea of the permeation rate, a #116 will lose approximately 30 psig over a period of one year (from 100 psig to 70 psig). Please see page 7 for a picture of a 1/4" NPT tank valve.

2. Three Point Regulated System The Airmounts can be connected directly to the factory compressed air system using pressure regulating valves. This eliminates the

need for periodic inspections. The air springs should always be connected in clusters so the mass is supported with only **THREE REGULATORS**. This is illustrated below (in the previous column) for both a four and eight Airmount system:

3. Three Point Levelled System Height control can be provided by adding height control valves to the system. Again, there should be only **THREE POINTS OF CONTROL**, or in this case, three leveling valves. Attempting to use more than three control points often results in the valves hunting or fighting one another. There are sensing systems available to control heights within ± 0.001 inch. Truck type leveling valves can provide accuracy to $\pm 1/16$ inch. A three point, eight air spring, leveled system is illustrated below:

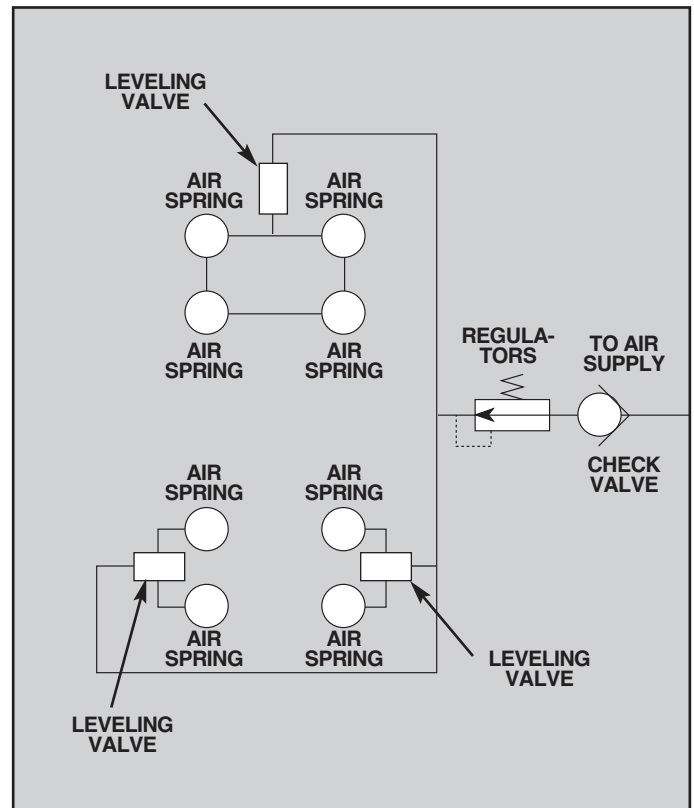
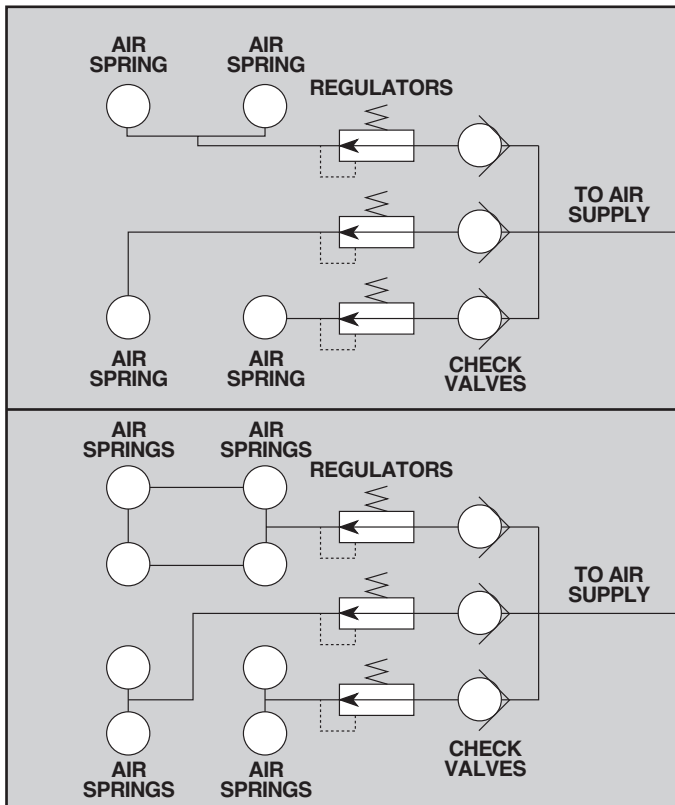

Description	Order No.
Time Delay Valve	WC1-358-3592

An Airmount Design Parameter Worksheet can be found on page 107.

AIRMOUNT™ VIBRATION ISOLATION

ISOLATION CHART

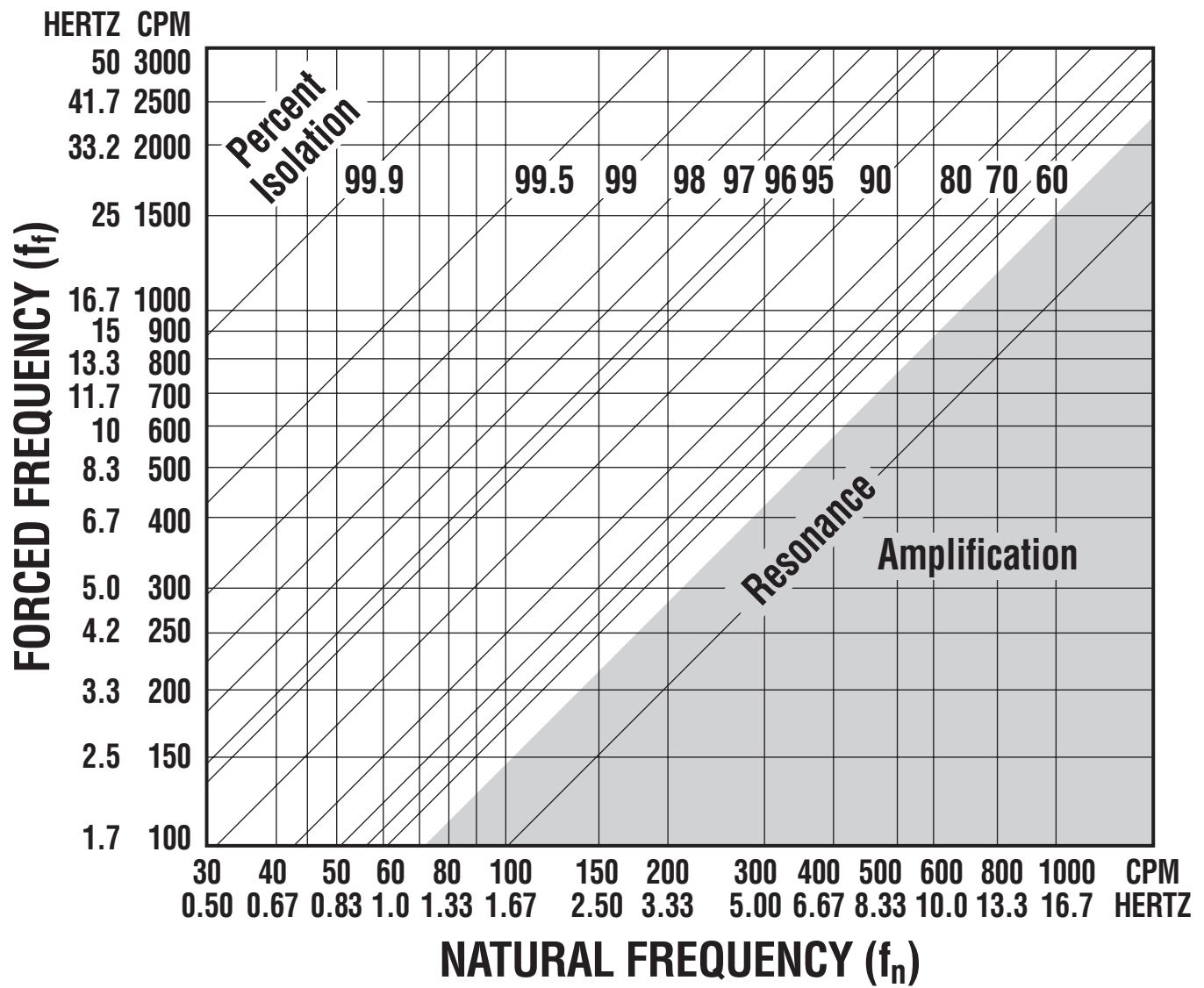

AIRMOUNT™ ISOLATION PROBLEM SOLVERS

VIBRATING PACKER



BIN HOPPER

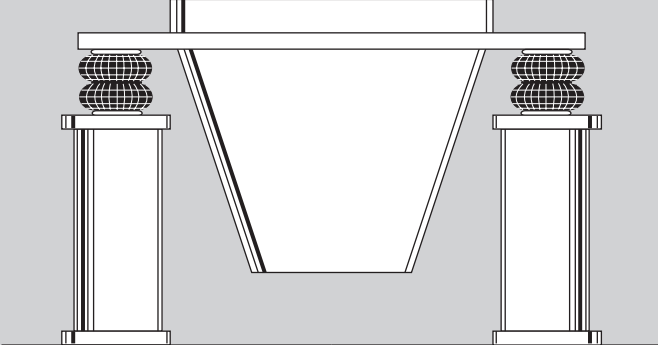

COMPRESSOR

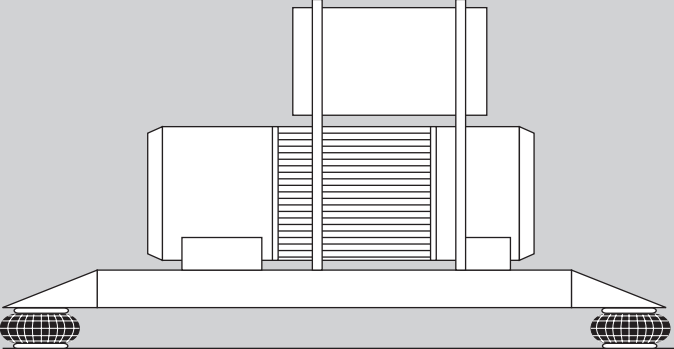

COMMERCIAL LAUNDRY MACHINE

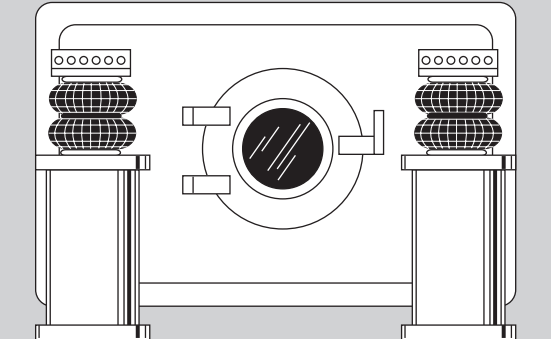

AIRMOUNT™ ISOLATION PROBLEM SOLVERS

CONTROL BOOTH



VIBRATING SCREEN



BLOWER AND MOTOR



CONTROL PANEL



MISCELLANEOUS APPLICATIONS

The air spring provides a unique solution for many actuation and isolation applications the world over. Besides the common applications, there are many that are not readily recognized because of the air spring's unique construction. Listed below are some miscellaneous applications.

SHOCK IMPACT ISOLATION

The air spring is frequently used in shock impact isolation applications. This air spring application is commonly found in saw mills as the means to both absorb the shock of a falling log, and then by actuating the air spring, to lift and transfer a log onto a conveyor. Because of the properties of both air and rubber, the air spring is an ideal solution to this problem. Without it, the mechanism and surrounding structure would suffer fatigue and fail prematurely due to the intensity of the shock from the falling log. Refer to the problem solver section on the following pages for miscellaneous applications.

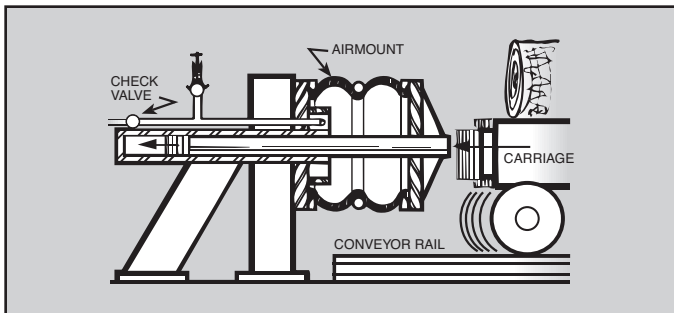

PROTECTIVE BOOT AND FLEXIBLE CONNECTOR

An air spring bellows, with a bead ring type attachment, can be used as a protective boot or flexible connector. Due to the flexible construction of the air spring and the ability to handle both misalignment and angular movement, the air spring is a suitable solution to this problem. To protect the inner surface from the flow of material, an inner sleeve may be required. Refer to the problem solver section on the following pages for miscellaneous applications.

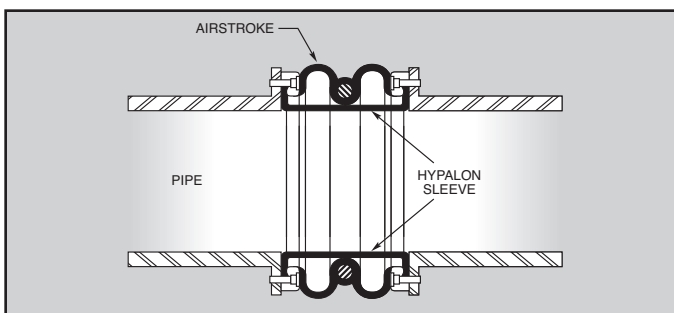

VACUUM PUMP

It is possible to drive an air spring mechanically in order to create a vacuum. The air spring can withstand a small amount of acceptable vacuum without injury to the bellows. The maximum amount of tolerable vacuum is dependent upon the bellows' size, height and whether it is a 2 ply or high strength air spring. It is generally best to use only the single convoluted air spring for this purpose. Refer to the problem solver section on the following pages for miscellaneous applications.

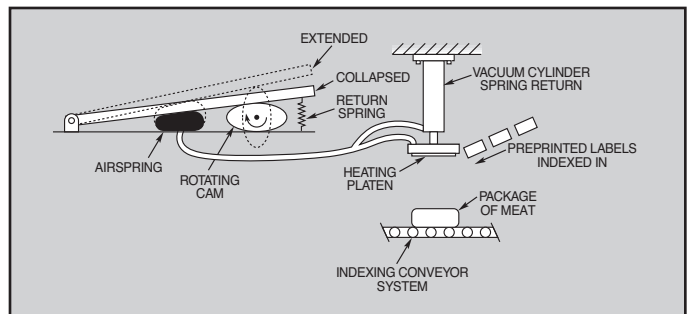

INFLATABLE CHUCK

By restricting the height internally of a bead ring style air spring, the rubber walls will extend in an outward fashion. In this arrangement the air spring can be used as an inflatable chuck. The air will need to be introduced via the same mechanism that restrains the air spring's height. Refer to the problem solver section on the following pages for miscellaneous applications.

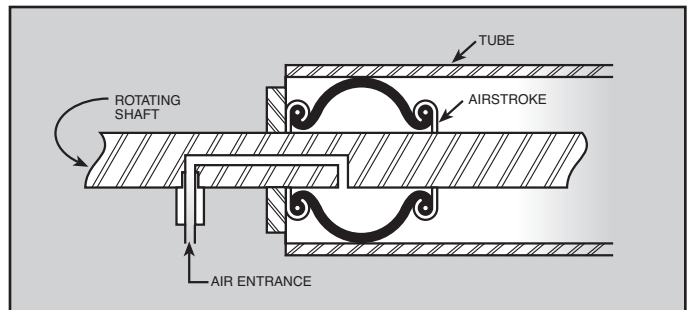

CAM FOLLOWER

The introduction of an air spring as the cam follower can extend the life of the cam greatly. Surface wear is reduced by removing the rigidity and friction of typical cam followers. With this reduction of wear comes continually smooth operations and overall minimization of fatigue. Refer to the problem solver section on the following pages for miscellaneous applications.

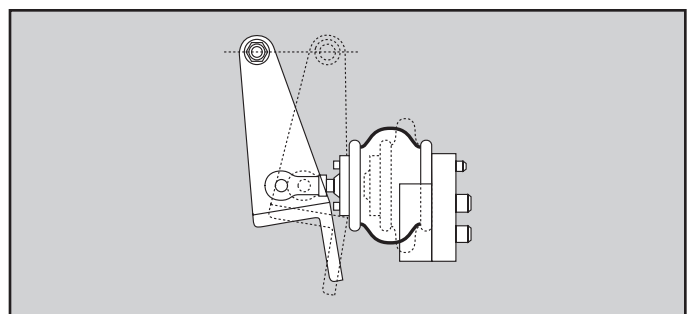

For more information, call your local stocking distributor or the Firestone applications engineer at the phone number on the back cover of this design guide.

MISCELLANEOUS PROBLEM SOLVERS

ROBOTIC COUPLING

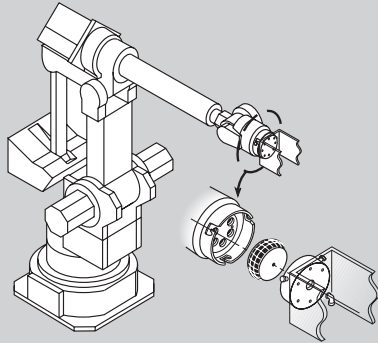

CONVEYOR END STOP

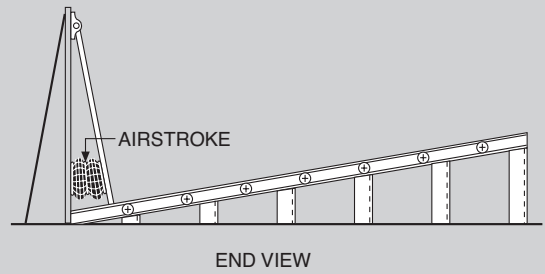

MOUNTAIN/TRAIL BIKE

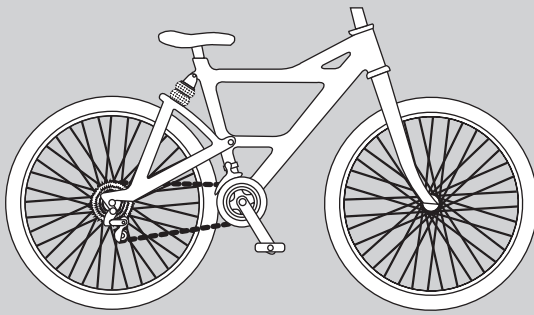

SHOCK ABSORBER TEST SYSTEM

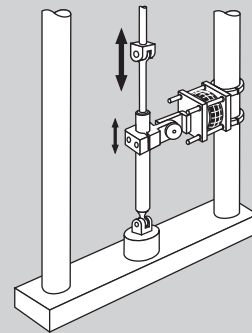

SCREENING MACHINE COVER CLAMP

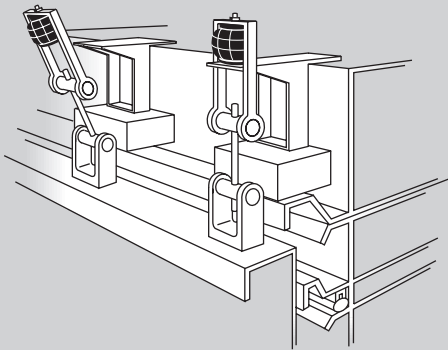

PIPE CRAWLER

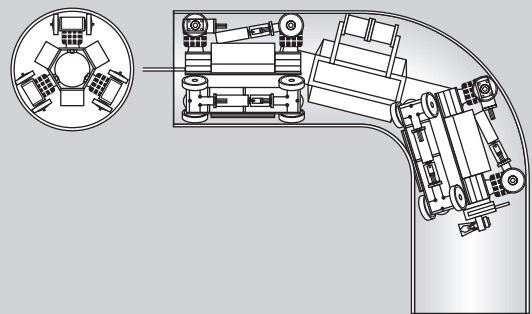

DELICATE ELECTRONIC EQUIPMENT

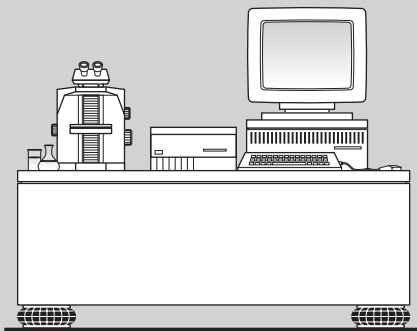

VIBRATING SCREEN

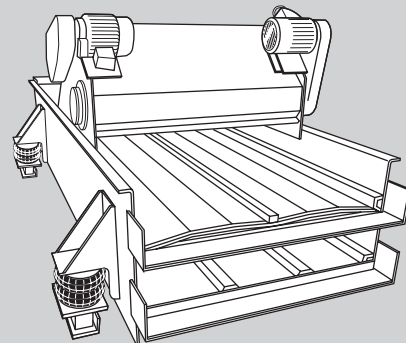

MISCELLANEOUS PROBLEM SOLVERS

SHEET WELDING CLAMP

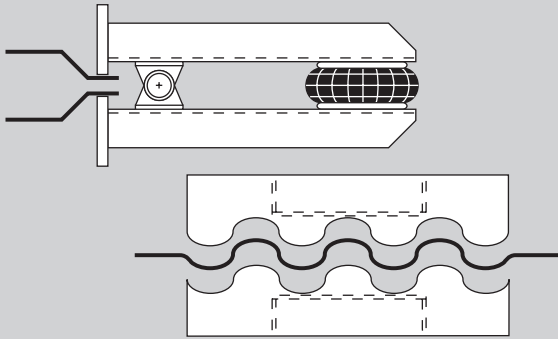

SWASH PLATE MOTOR

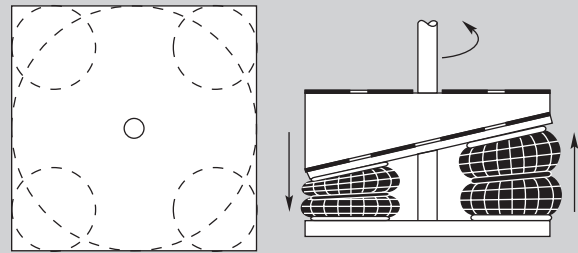

PERFECT BOUND MAGAZINE CUTTER

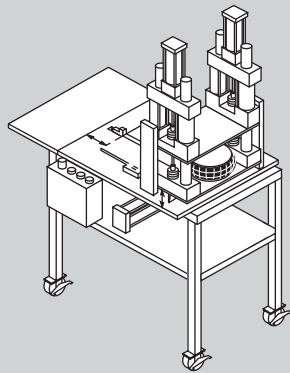

WAVE POWER MODULE

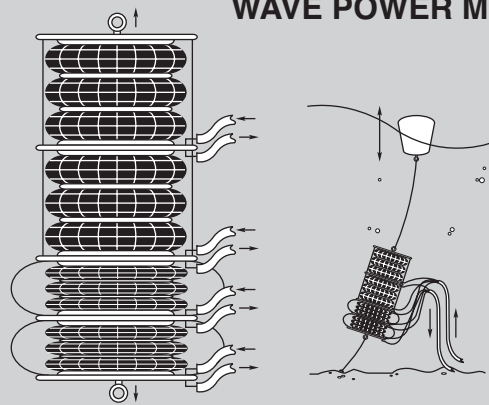

CHECK VALVE LAPPING

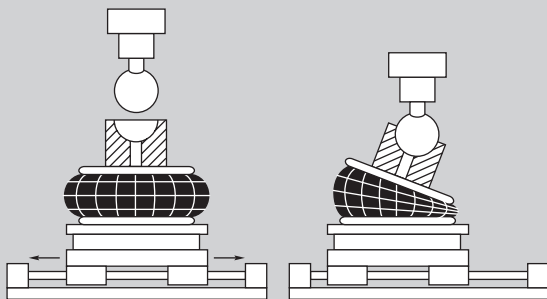

SELF ALIGNING DEVICE

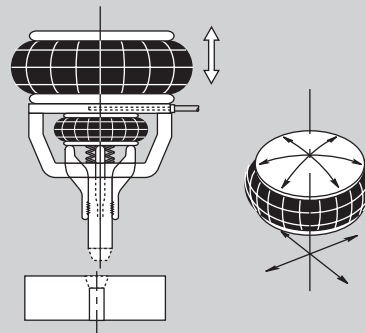

AIR BLAST GENERATOR



SOLAR TRACKER

