

QUINT-PS/ 1AC/24DC/ 5/CO

Power supply unit, dip coated

INTERFACE

Data sheet
105395_en_00

© PHOENIX CONTACT 2012-09-07



1 Description

QUINT POWER power supply units provide loads in the control cabinet with a constant power supply.

For the first time ever, even standard circuit breakers can be tripped reliably and quickly with SFB (selective fuse breaking) technology and six times the nominal current for 12 ms. Faulty current paths are switched off selectively, the fault is located, and important system parts remain in operation.

Features

Maximum system availability

- Using SFB technology (6 times the nominal current for 12 ms), circuit breakers are tripped quickly and important system parts remain in operation
- Through the preventive monitoring of output voltage and current and the transmission of critical operating states to the controller
- Through reliable starting of difficult loads with POWER BOOST power reserve
- Long mains buffering > 30 ms
- High MTBF > 635,000 h

Worldwide use

- Input voltage from 85 V AC ... 246 V AC
- Input voltage from 90 V DC ... 350 V DC

Flexible use

- Dip coating enables use in oxidizing and sulfidizing atmospheres with humidities of up to 100%
- Adjustable output voltage
- ATEX approval $\text{Ex II 3 G Ex nA nC IIC T4 Gc}$
- Can be used in Class I, Division 2, Groups A, B, C, D (Hazardous Location) ANSI-ISA 12.12



Make sure you always use the latest documentation.
It can be downloaded from the product at www.phoenixcontact.net/catalog.

2	Table of contents	
1	Description	1
2	Table of contents	2
3	Ordering data	3
4	Technical data	4
5	Safety regulations and installation notes.....	8
6	Structure.....	9
7	Basic circuit diagram	9
8	Installation	10
	8.1 Convection.....	10
	8.2 Mounting position	11
	8.3 Mounting on a DIN rail	11
	8.4 Connection to different systems	12
9	Device connection terminal blocks	13
	9.1 AC input	13
	9.2 DC output	13
10	Signaling.....	14
	10.1 Active signal outputs.....	14
	10.2 Signal loop.....	14
11	Function.....	15
	11.1 Output characteristic curve.....	15
	11.2 SFB technology.....	15
	11.3 Temperature response.....	15
	11.4 Parallel operation.....	15

3 Ordering data

Description	Type	Order No.	Pcs. / Pkt.
QUINT power supply unit for DIN rail mounting, input: primary-switched, 1-phase, output: 24 V DC/5 A, dip coated circuit board, with integrated SFB (selective fuse breaking) technology including mounted universal DIN rail adapter UTA 107/30	QUINT-PS/ 1AC/24DC/ 5/CO	2320908	1

Accessories	Type	Order No.	Pcs. / Pkt.
Universal DIN rail adapter	UTA 107/30	2320089	25
Universal wall adapter	UWA 182/52	2938235	1
Assembly adapter for QUINT-PS... power supply on S7-300 rail	QUINT-PS-ADAPTERS7/1	2938196	1
The fan for QUINT-PS/1AC and .../3AC can be mounted without the need for tools or other accessories. By using the fan, optimum cooling is ensured at high ambient temperatures or if the mounting position is rotated.	QUINT-PS/FAN/4	2320076	1
Active redundancy module with ACB technology and monitoring functions	QUINT-ORING/24DC/2X10/1X20	2320173	1
DIN rail diode module 12-24 V DC/2x20 A or 1x40 A. Uniform redundancy up to the consumer.	QUINT-DIODE/12-24DC/2X20/1X40	2320157	1
Redundancy module with function monitoring, 12-24 V DC, 2x 10 A, 1x 20 A	TRIO-DIODE/12-24DC/2X10/1X20	2866514	1
Thermomagnetic device circuit breaker, 1-pos., tripping characteristic SFB, 1 PDT contact, plug for base element.	CB TM1 1A SFB P	2800836	1
Thermomagnetic device circuit breaker, 1-pos., tripping characteristic SFB, 1 PDT contact, plug for base element.	CB TM1 2A SFB P	2800837	1



Our range of accessories is being continually extended, our current range can be found in the download area.

4 Technical data

Input data	
Nominal input voltage range	100 V AC ... 240 V AC
AC input voltage range	85 V AC ... 264 V AC
Short-term input voltage	300 V AC
DC input voltage range	90 V DC ... 350 V DC (UL 508: ≤ 250 V DC)
AC frequency range	45 Hz ... 65 Hz
DC frequency range	0 Hz
Current consumption	1.2 A (120 V AC) 0.6 A (230 V AC)
Inrush current limitation	< 15 A (typical)
I^2t	< 1 A ² s
Power failure bypass	> 30 ms (120 V AC) > 30 ms (230 V AC)
Typical response time	< 0.5 s
Protective circuit	Transient surge protection Varistor
Input fuse, integrated	5 A (slow-blow, internal)
Discharge current to PE	< 3.5 mA
Output data	
Nominal output voltage	24 V DC ±1%
Setting range of the output voltage	18 V DC ... 29.5 V DC (> 24 V constant capacity)
Output current	5 A (-25°C ... 60°C, U _{OUT} = 24 V DC) 7.5 A (with POWER BOOST, -25°C ... 40°C permanently, U _{OUT} = 24 V DC) 7.5 A (U _{IN} ≥ 100 V AC) 30 A (SFB technology, 12 ms)
Magnetic fuse tripping	C2
Control deviation	< 1 % (change in load, static 10% ... 90%) < 2 % (change in load, dynamic 10% ... 90%) < 0.1 % (change in input voltage ±10%)
Efficiency	> 90 % (for 230 V AC and nominal values)
Ascent time	< 0.5 ms
Residual ripple	< 40 mV _{PP} (with nominal values)
Connection in parallel	Yes, for redundancy and increased capacity
Connection in series	Yes
Protection against surge voltage on the output	< 35 V DC
Resistance to reverse feed	max. 35 V DC
Power consumption	
Maximum power dissipation NO-Load	3 W
Power loss nominal load max.	15 W
DC OK active	
Output description	U _{OUT} > 0.9 x U _N : High signal
Voltage/current	18 V DC ... 24 V DC / 20 mA (short-circuit resistant)
Status display	U _{OUT} > 0.9 x U _N : "DC OK" LED green / U _{OUT} < 0.9 x U _N : Flashing "DC OK" LED
DC OK floating	
Output description	Relay contact, U _{OUT} > 0.9 x U _N : Contact closed
Voltage/current	30 V AC / 0.5 A , 24 V DC / 1 A (ATEX/IECEX: Ohmic loads only)
Status display	U _{OUT} > 0.9 x U _N : "DC OK" LED green / U _{OUT} < 0.9 x U _N : Flashing "DC OK" LED

POWER BOOST, active

Output description	$I_{OUT} < I_N$: High signal
Voltage/current	18 V DC ... 24 V DC / 20 mA (short-circuit resistant)
Status display	$I_{OUT} > I_N$: LED "BOOST" yellow

General data

Insulation voltage input/output	4 kV AC (type test) 2 kV AC (routine test)
Insulation voltage input / PE	4 kV AC (type test) 2 kV AC (routine test)
Insulation voltage output / PE	500 V DC (routine test)
Degree of protection	IP20
Protection class	I
MTBF	> 635000 h (According to IEC 61709)
Type of housing	Steel sheet, zinc-plated
Housing material	Steel sheet, zinc-plated
Dimensions W / H / D (state of delivery)	40 mm / 130 mm / 125 mm
Dimensions W / H / D (90° turned)	122 mm / 130 mm / 43 mm
Weight	0.7 kg









Ambient conditions

Ambient temperature (operation)	-25 °C ... 70 °C (ATEX / IECEx < 60 °C)
Ambient temperature (storage/transport)	-40 °C ... 85 °C
Max. permissible relative humidity (operation)	100 % (at 25 °C, no condensation)
Vibration (operation)	< 15 Hz, amplitude ± 2.5 mm (according to IEC 60068-2-6) 15 Hz ... 150 Hz, 2.3g, 90 min.
Shock	30 g in each direction, according to IEC 60068-2-27
Pollution degree	2
Climatic class	3K3 (in acc. with EN 60721)

Standards

Electrical Equipment for Machinery	EN 60204 / Surge voltage category III
Electrical safety (of information technology equipment)	IEC 60950-1/VDE 0805 (SELV)
Electronic equipment for use in electrical power installations	EN 50178/VDE 0160 (PELV)
SELV	IEC 60950-1 (SELV) and EN 60204 (PELV)
Safe isolation	DIN VDE 0100-410 DIN VDE 0106-1010
Protection against electric shock	DIN 57100-410
Protection against electric shock, basic requirements for safe isolation in electrical equipment	DIN VDE 0106-101
Limitation of mains harmonic currents	EN 61000-3-2
Network version/undervoltage	SEMI F47-0706 Compliance Certificate; EN 61000-4-11
Information technology equipment - Safety (CB Scheme)	IEC 60950 (2 nd Edition)
Medical standard	IEC 60601
Explosive atmospheres	EN 60079-15 (Zone 2)

Approvals

ATEX	 II 3 G Ex nA nC IIC T4 Gc TÜV 11 ATEX 555674 X
IECEX	Ex nA nC IIC T4 Gc IECEX TUN 11.0002X
UL	UL/C-UL listed UL 508 UL/C-UL Recognized UL 60950 UL ANSI/ISA-12.12.01 Class I, Division 2, Groups A, B, C, D (Hazardous Location)
CSA	CAN/CSA-C22.2 No. 60950-1-07 CSA-C22.2 No. 107.1-01
SIQ	BG (type approved) IEC 60950 (2 nd Edition)
Shipbuilding	Germanischer Lloyd (EMC 2)
DeviceNet	DeviceNet™ Power Supply Conformance Tested
	      

Conformance with EMC Directive 2004/108/EC		
Noise immunity according to EN 61000-6-2		
	EN 61000-6-2 requirement	Tested
Electrostatic discharge EN 61000-4-2		
Housing contact discharge	4 kV (Test intensity 2)	8 kV (Test intensity 4)
Housing air discharge	8 kV (Test intensity 3)	8 kV (Test intensity 3)
Comments	Criterion B	Criterion A
Electromagnetic HF field EN 61000-4-3		
Frequency range	80 MHz ... 1 GHz	80 MHz ... 1 GHz
Test field strength	10 V/m	20 V/m
Frequency range	1.4 GHz ... 2 GHz	1 GHz ... 2 GHz
Test field strength	3 V/m	10 V/m
Frequency range	2 GHz ... 2.7 GHz	2 GHz ... 3 GHz
Test field strength	1 V/m	10 V/m
Comments	Criterion A	Criterion A
Fast transients (burst) EN 61000-4-4		
Input	2 kV (Test intensity 3 - asymmetrical)	4 kV (Test intensity 4 - asymmetrical)
Output	2 kV (Test intensity 3 - asymmetrical)	2 kV (Test intensity 3 - asymmetrical)
Signal	1 kV (Test intensity 3 - asymmetrical)	2 kV (Test intensity 4 - asymmetrical)
Comments	Criterion B	Criterion A
Surge current loads (surge) EN 61000-4-5		
Input	1 kV (Test intensity 2 - symmetrical) 2 kV (Test intensity 3 - asymmetrical)	2 kV (Test intensity 3 - symmetrical) 4 kV (Test intensity 4 - asymmetrical)
Output	0.5 kV (Test intensity 1 - symmetrical) 0.5 kV (Test intensity 1 - asymmetrical)	1 kV (Test intensity 2 - symmetrical) 2 kV (Test intensity 3 - asymmetrical)
Signal	1 kV (Test intensity 2 - asymmetrical)	1 kV (Test intensity 2 - asymmetrical)
Comments	Criterion B	Criterion A
Conducted interference EN 61000-4-6		
Input/Output/Signal	Level 3 - asymmetrical	asymmetrical
Frequency range	0.15 MHz ... 80 MHz	0.15 MHz ... 80 MHz
Voltage	10 V	10 V (Test intensity 3)
Comments	Criterion A	Criterion A
Voltage dips EN 61000-4-11		
Comments	Criterion B	Criterion B
Emitted interference in acc. with EN 61000-6-3		
Radio interference voltage in acc. with EN 55011	EN 55011 (EN 55022) Class B, area of application: Industry and residential	
Emitted radio interference in acc. with EN 55011	EN 55011 (EN 55022) Class B, area of application: Industry and residential	

5 Safety regulations and installation notes



DANGER OF EXPLOSION!

Only remove equipment when it is disconnected and not in the potentially explosive area.

DANGER

Never carry out work on live parts!
The housing can become very hot, depending on the ambient temperature and load!



CAUTION:

Before startup please ensure:

The connection must be carried out by a competent person and protection against electric shock guaranteed.

It must be possible to switch off power to device according to EN 60950.

All feed lines are sufficiently protected and dimensioned!

All output lines are dimensioned according to the maximum output current of the device or separately protected!

Sufficient convection must be guaranteed.

Observe mechanical and thermal limits.



ATTENTION: Danger if used improperly

The power supply units are built-in devices. The device may only be installed and put into operation by qualified personnel. The corresponding national regulations must be observed.



CAUTION: Risk of injury

Cover termination area after installation in order to avoid accidental contact with live parts (e. g., installation in control cabinet).



Warning: Explosion hazard!

Install the device in a suitable approved housing (with at least IP54 protection) that meets the requirements of EN 60079-15.

The device must be stopped and immediately removed from the Ex area if it is damaged or was subject to an impermissible load or stored incorrectly or if it malfunctions.

The device is designed for installation in zone 2 potentially explosive areas according to Directive 94/9/EC.

6 Structure

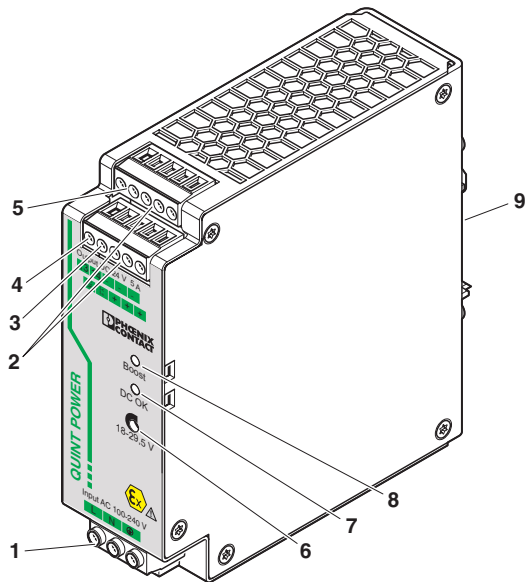
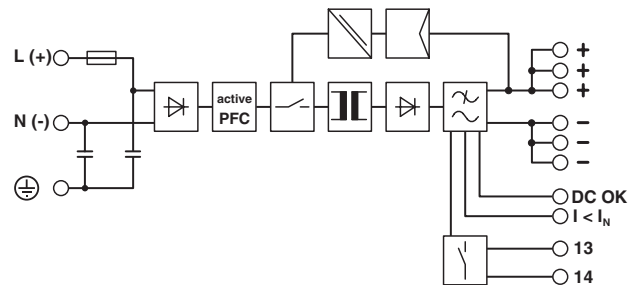

Figure 1 Position of the function elements

No.	Connection terminal blocks and function elements
1	AC input
2	DC output
3	Active signal output $I < I_N$ (POWER BOOST)
4	Active DC OK signal output
5	Floating DC OK switching output
6	Potentiometer for setting the output voltage
7	DC OK signal LED, green
8	Signal LED boost, yellow
9	Universal DIN rail adapter

7 Basic circuit diagram



Element	Meaning
	Rectification
	Power factor correction filter
	Switch
	Disconnect transducer
	Controller
	Transmitter
	Output filter
	Floating switching output

8 Installation

8.1 Convection

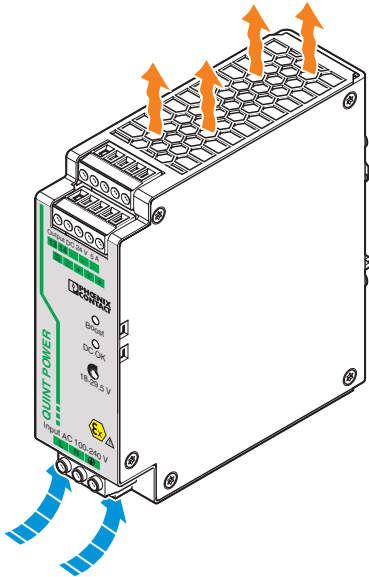

Figure 2 Convection



NOTE: enable convection

The housing can become very hot, depending on the ambient temperature and module load.

To enable sufficient convection, we recommend a minimum vertical clearance of 50 mm from other modules. In order to ensure proper functioning of the module, it is necessary to maintain a lateral distance of 5 mm and 15 mm for active components.



The device can be snapped onto all DIN rails in accordance with EN 60715 and should be mounted in the normal mounting position (connection terminal blocks on top and bottom).

8.2 Mounting position

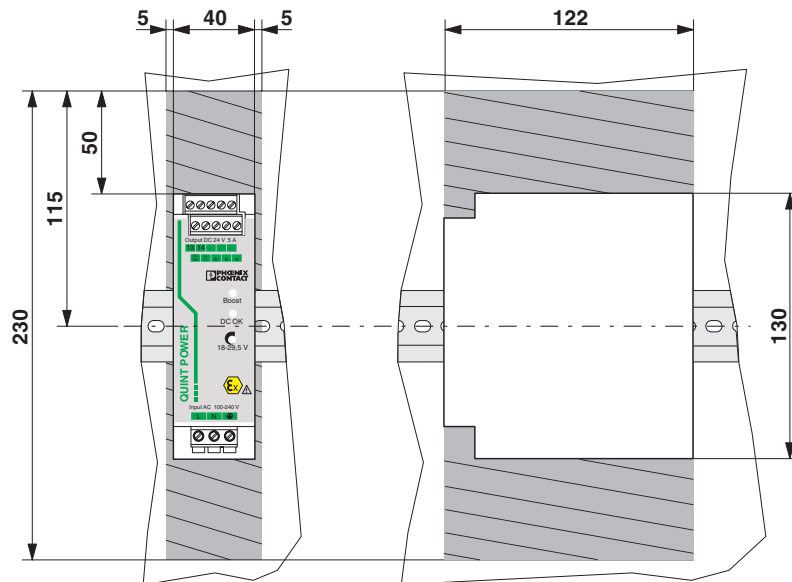

Possible mounting positions:

Normal mounting position: installation depth of 125 mm (+ DIN rail)

Mounting position rotated at 90°: installation depth of 43 mm (+ DIN rail)

8.3 Mounting on a DIN rail

Normal mounting position

Assembly

Position the module with the DIN rail guide on the upper edge of the DIN rail, and snap it in with a downward motion.

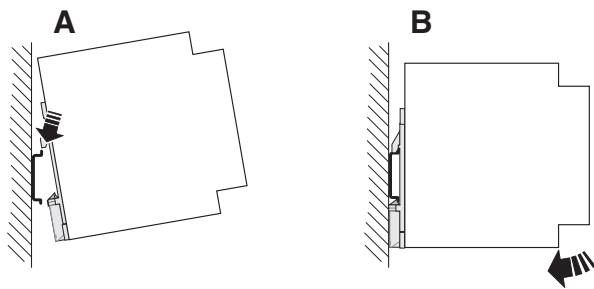

Figure 3 Assembly

Removing

Pull the snap lever open with the aid of a screwdriver and slide the module out at the lower edge of the DIN rail.

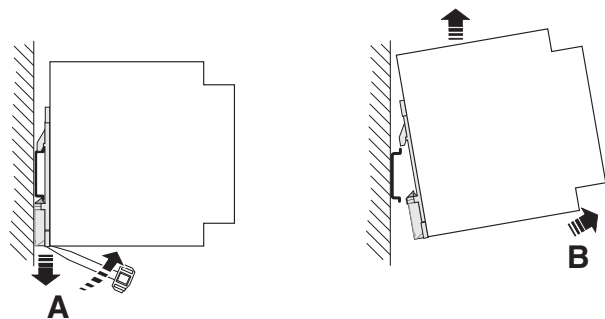

Figure 4 Removal

Mounting position rotated 90°

For a mounting position rotated at 90° to the DIN rail, mount the DIN rail adapter (UTA 107) as shown in the figure. No additional assembly material is required. Mounting screws: Torx® T10 (0.8 Nm ... 0.9 Nm tightening torque).

8.4 Connection to different systems

The device can be connected to 1-phase AC networks or to two of the phase conductors of 3-phase systems (TN, TT or IT system according to VDE 0100-300/IEC 60364-3) with nominal voltages of 100 V AC ... 240 V AC.



For operation on two of the phase conductors of a three-phase system, an isolating facility for all poles must be provided.

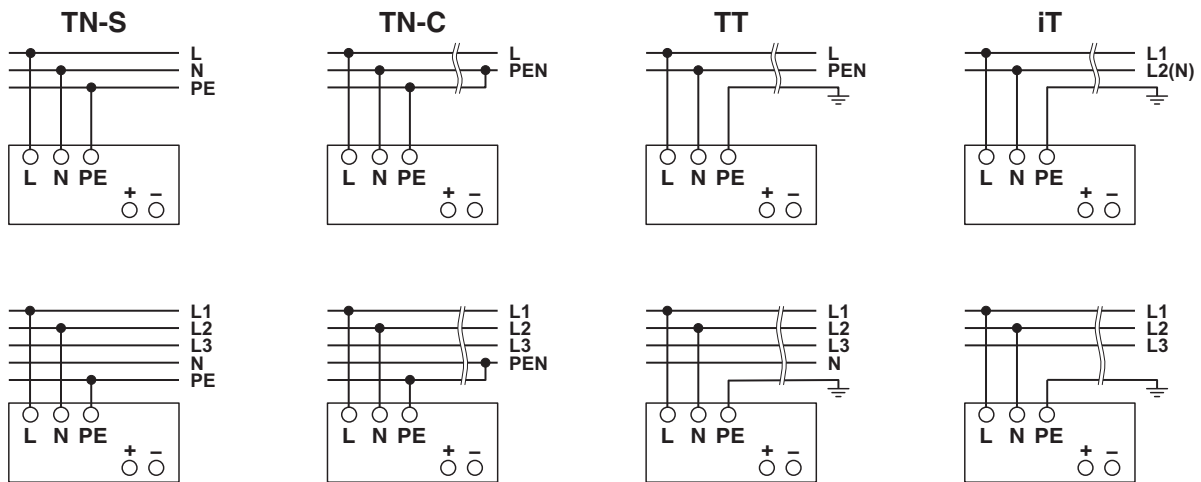

9 Device connection terminal blocks

9.1 AC input

The supply voltage is connected via "Input AC 100 - 240 V" connection terminal blocks.

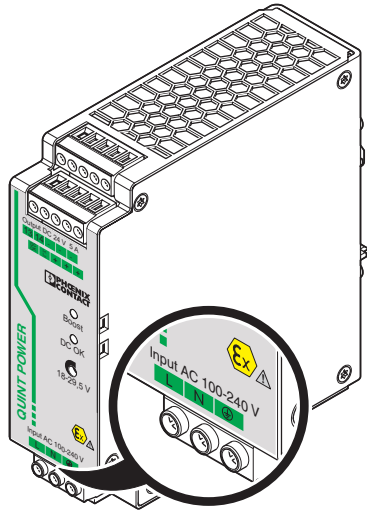

Protection of the primary side

The device must be installed in acc. with the regulations as in EN 60950. It must be possible to disconnect the device using a suitable isolating facility outside the power supply. Primary circuit mains protection, for example, is suitable for this purpose.

An internal fuse is provided for device protection. Additional device protection is not required.

Permissible backup fuse for mains protection

Power circuit-breaker 6 A, 10 A or 16 A, characteristic B (or identical function).

Connect a suitable fuse upstream for DC applications!



CAUTION:

If an internal fuse is triggered, there is a device malfunction. In this case, the device must be inspected in the factory.

9.2 DC output

The output voltage is connected via the "Output DC" connection terminal blocks.

The device is short-circuit-proof and idling-proof.

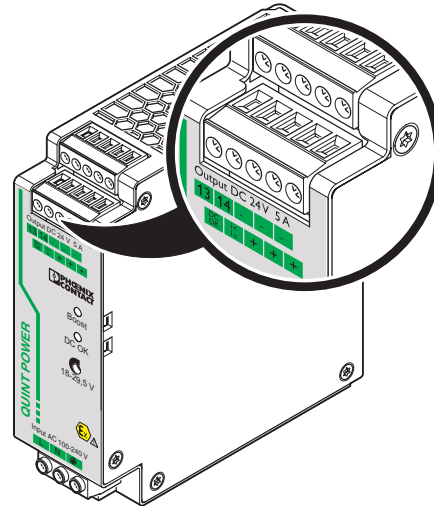

10 Signaling

The following are available for function monitoring:

- The active signal output DC OK
- The floating DC OK output
- The active POWER BOOST signal output

In addition, the "DC OK" and "BOOST" LEDs can be used to evaluate the function of the power supply directly at the installation location (see output characteristic curve)



If the output voltage falls below 90% of the output voltage set on the potentiometer as a result of overloading, the signal state "DC OK" switches from "Active High" to "Low". The limit value of 90% always refers to the set output voltage range of 18 V DC to 29.5 V DC.

	Normal operation $I < I_N$	POWER BOOST $I > I_N$	Overload mode $U_{OUT} < 0.9 \times U_N$
"DC OK" LED, green	Lit	Lit	Flashing
"BOOST" LED, yellow	OFF	Lit	Lit
"DC OK" signal	ON	ON	OFF
"DC OK" relay	closed	closed	opened
Signal " $I < I_N$ "	ON	OFF	OFF
Meaning	Normal operation of the power supply unit ($U_{OUT} > 21.5$ V)	POWER BOOST mode, e.g., for starting loads	Overload mode, e.g., load short circuit or overload

Floating switch contact

The floating switch contact opens to indicate that the set output voltage has been undershot by more than 10% ($U_{OUT} < 0.9 \times U_N$). Signals and ohmic loads can be switched. For heavily inductive loads such as a relay, a suitable protective circuit (e.g., freewheeling diode) is necessary.

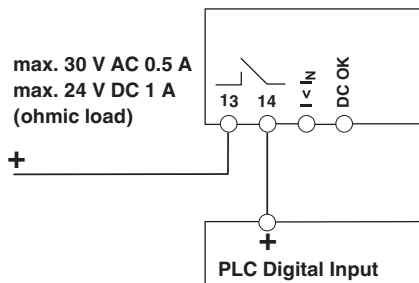

10.1 Active signal outputs

For the transmission of signals to a higher-level controller, the active "DC OK" and "Boost" signal outputs can be used.

The 18 ... 24 V DC signal is applied between the "DC OK" and "-" (active DC OK signal output) or between " $I < I_N$ " and "-" (active POWER BOOST signal output) and can withstand a maximum of 20 mA.

By switching from "active high" to "low", the DC OK signal output indicates that the set output voltage has been undershot by more than 10% ($U_{OUT} < 0.9 \times U_N$). The DC OK signal is decoupled from the power output. This makes it impossible for devices connected in parallel to act as an external power supply.

The BOOST signal output " $I < I_N$ " indicates that the nominal current has been exceeded. The power supply then switches to POWER BOOST mode. Thanks to this preventive function monitoring, critical operating states can be recognized at an early stage, prior to a voltage dip occurring.

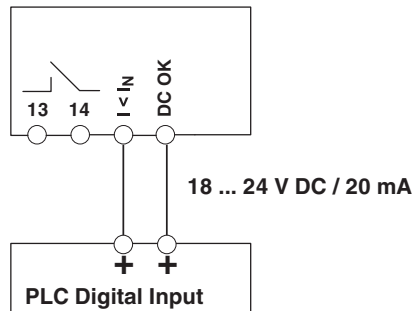

10.2 Signal loop

Monitoring of two devices: use the active DC OK signal output of device 1 and loop the floating alarm output of device 2. In the event of a malfunction, you will receive a group error message. Any number of devices can be looped. This signal combination saves wiring costs and logic inputs.

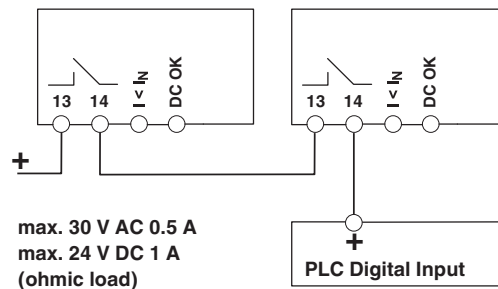

11 Function

11.1 Output characteristic curve

The module functions according to the U/I characteristic curve with the static POWER BOOST power reserve. At a constant output voltage U_N , I_{BOOST} is available. This I_{BOOST} current supplies up to 1.5 times the I_N nominal output current. High inrush currents are therefore absorbed without voltage dips.

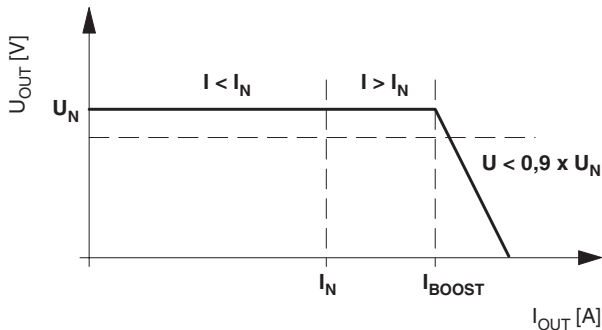

$U_N = 24\text{ V}$

$I_N = 5\text{ A}$

$I_{BOOST} = 7.5\text{ A}$

SFB technology = 30 A (12 ms)

$P_N = 120\text{ W}$

$P_{Boost} = 180\text{ W}$

11.2 SFB technology

In order to trip standard circuit breakers magnetically and therefore very quickly, modules with SFB technology provide up to six times the nominal current I_N for 12 ms. This dynamic power reserve switches off faulty current paths and loads installed in parallel continue to run without interruption. The short circuit on the load is therefore located and important system parts remain in operation.

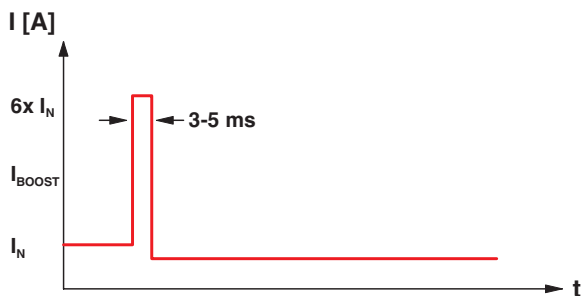

Release time = typically 3-5 ms

11.3 Temperature response

At an ambient temperature of -25°C to $+40^\circ\text{C}$, the device continuously supplies the I_{BOOST} output current. The device can supply the I_N nominal output current up to an ambient temperature of $+60^\circ\text{C}$. At ambient temperatures above $+60^\circ\text{C}$, the output power must be decreased by 2.5% per Kelvin increase in temperature. At ambient temperatures above $+70^\circ\text{C}$ or in the event of a thermal overload, the device does not switch off. The output power is decreased to such an extent that device protection is provided. Once the device has cooled down, the output power is increased again.

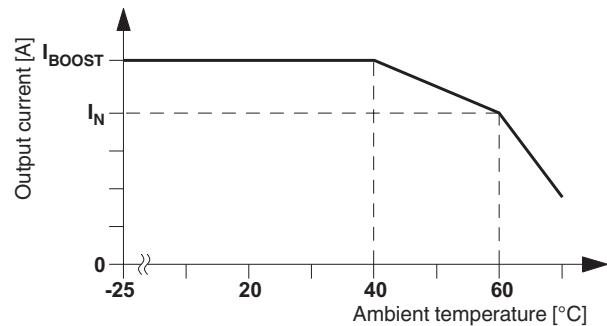

11.4 Parallel operation

Devices of the same type can be connected in parallel to increase both redundancy and power. No further adjustments are necessary for the default setting.

If the output voltage of a power supply unit is adjusted, all power supplies connected in parallel must be set to the same output voltage in order to ensure an even distribution of current.

In order to ensure symmetrical current distribution, we recommend that all cable connections from the power supply unit to the busbar are the same length and have the same cross section.

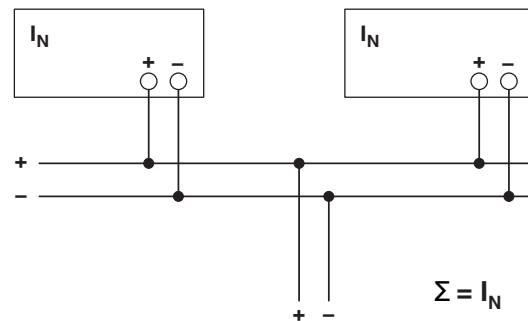

Redundant operation

Redundant circuits are suitable for supplying systems which place particularly high demands on operational safety. If a 1+1 redundancy is implemented, this means that for a load of 20 A, two modules each with 20 A must be connected in parallel on the output side. In the event of an internal device fault or failure of the mains power supply on the primary side, the second module automatically takes over the entire supply of the loads.

Example: diode module

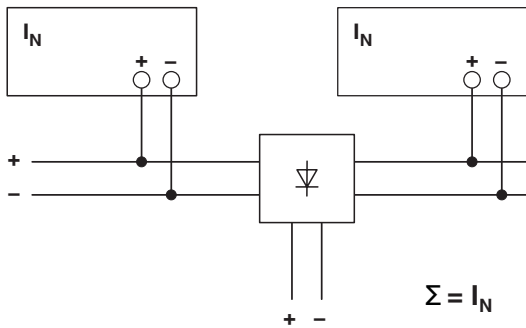

Increased performance

The output current can be increased to $n \times I_N$ in the case of n parallel connected devices. Parallel connection for increasing power is used when extending existing systems. A parallel connection is recommended if the power supply unit does not cover the current consumption of the most powerful load. Otherwise, the load should be distributed between individual devices that are independent from one another.

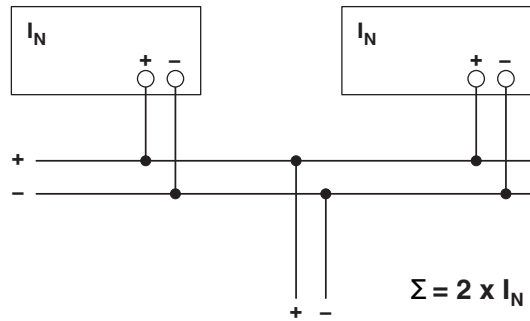

Example: QUINT ORING

