

FLOW SCHEMATIC:

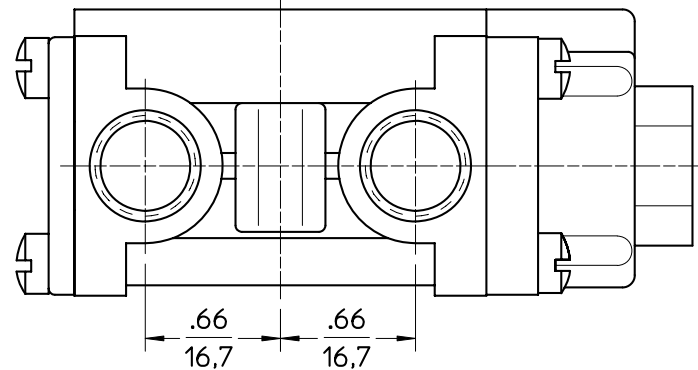
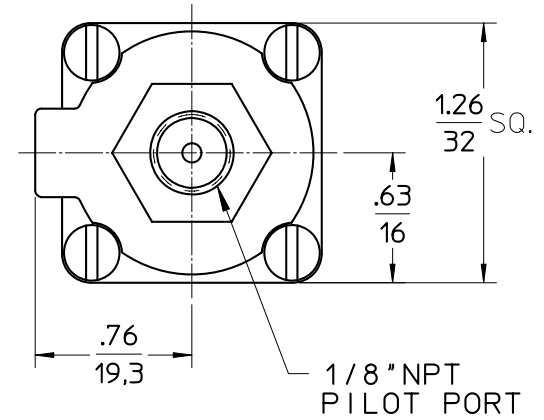
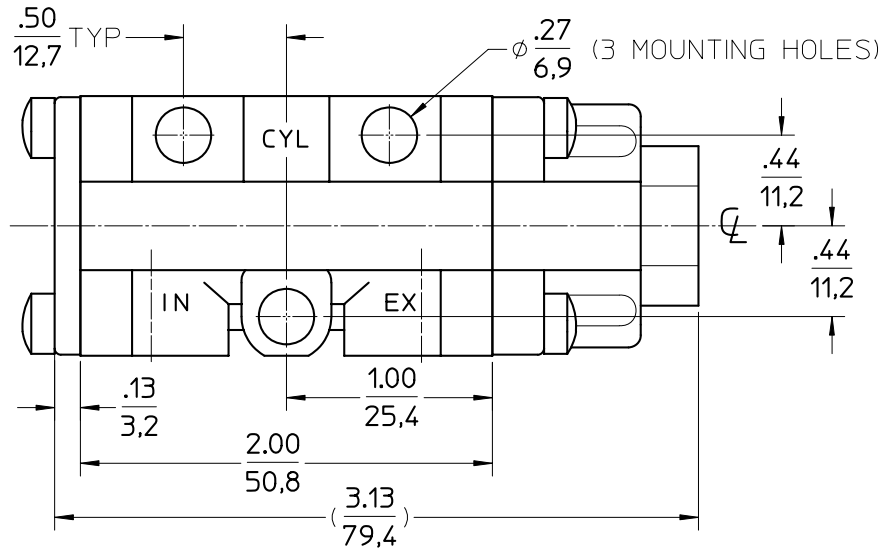
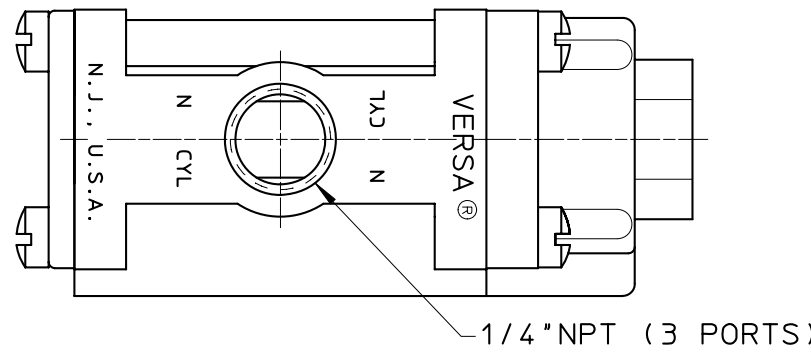
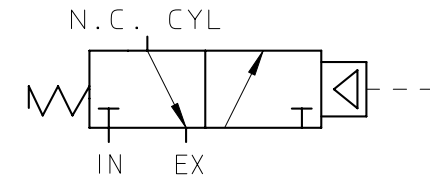

IN
mm

DRAWN BY 4-29-99 MR	CHECKED BY 5-6-99 JC	ENG APP'D 5-7-99 BN	ORIG EWR 10475	TITLE VALVE ASSEMBLY
MATL /	SCALE 1:1	NEXT ASSY	DWG SIZE A	
HARDNESS /	UNLESS OTHERWISE SPECIFIED 2 PLACE DECIMAL ±.010 ANGULAR DIMENSIONS ±1/2° 3 PLACE DECIMAL ±.003 BREAK CORNERS & EDGES .010 DIA'S ON SAME CENTERLINE CONCENTRIC WITHIN .006 T.I.R. MACHINED SURFACES FINISHED TO 64 RMS MAX. 150 NOT SCALE DRAWING			
HEAT TREAT /				
THIS DRAWING IS CAD GENERATED AND THE PROPERTY OF VERSA PRODUCTS CO. INC. USE AND/OR REPRODUCTION OF ANY PORTION MUST BE WITH THE APPROVAL OF VERSA				VERSA PRODUCTS CO., INC. PARAMUS N.J., U.S.A. VERSA BV, NETHERLANDS
REVISION LEVEL				DWG. NO. GB2-0001

NG 3-30-07	UPDATED DRAWING.	13918
JMC 4-2-07		AP 4-3-07
REV/CHKD BY	DESCRIPTION	EWR NO/APP'D BY

Refer to Master Copy Online for latest revision - Printed on: (02/29/14 02:04) Property of Versa Products