

## QUBE Series End / Wall Mount Brackets

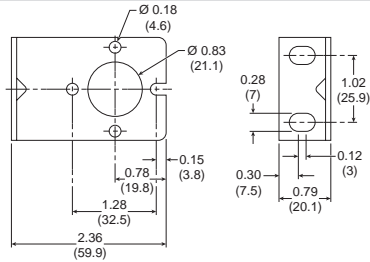

**35 Series Bracket - SAR35Y57**

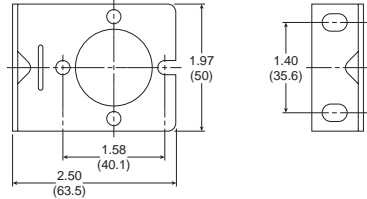

**75 Series Bracket - SAR75Y57**

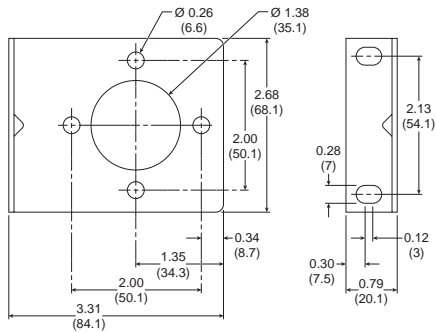

**105 Series Bracket - SAR105Y57**

QUBE FRL components have integral mounting slots that usually eliminate the need for mounting brackets. However, some applications may require the use of mounting brackets:

- Assemblies incorporating components from multiple series.
- Applications where the FRL needs to be spaced away from the machine.

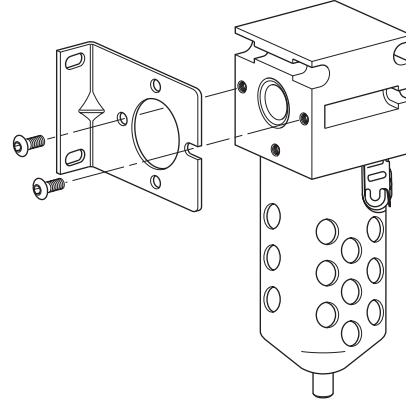

**Bracket Installation**

## QUBE Series Panel Mount Brackets

These brackets are designed to mount regulators and integral filter / regulators using panel mount threads on spring cage.

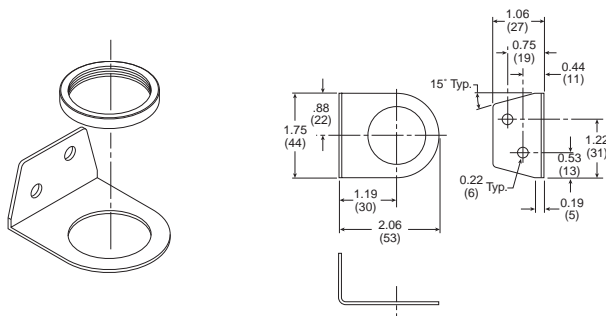

**35 & 75 Series QUBE**

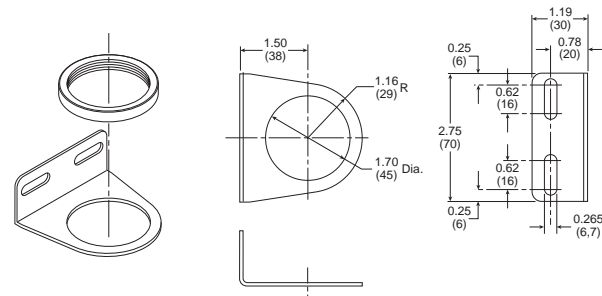

**105 Series QUBE**

Part Number: **SA161X57**  
 (Comes complete with R05X51-P Plastic Panel Nut)

Part Number: **SAR10Y57**  
 (Comes complete with R10X51-P Plastic Panel Nut)